

246-EN

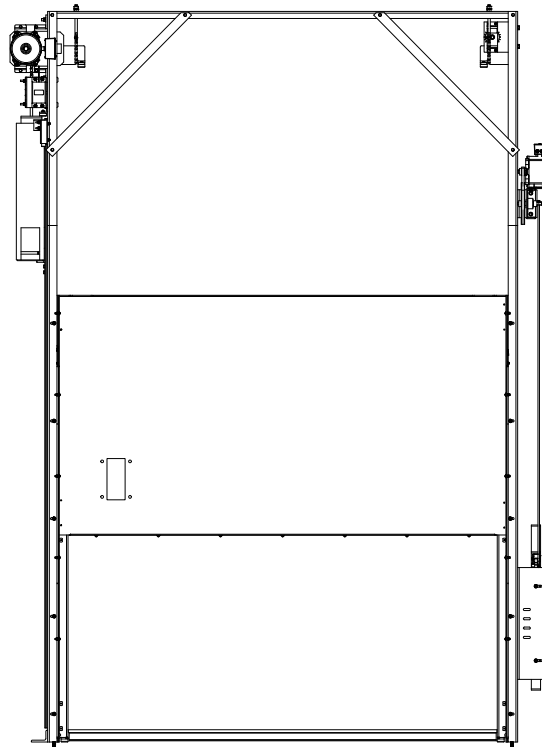

2 SECTION SLIDE-UP CAR DOOR INSTALLATION GUIDE



THE PELLE COMPANY

FREIGHT DOORS | CAR GATES | CAR ENCLOSURES

TECHNICAL SUPPORT 1-800-787-5020 ext 275

Guide No. 246-EN

2 SECTION SLIDE-UP CAR DOOR
INSTALLATION GUIDE

Date: May 15 / 2018

Contents

1. FORWARD	1
2. BEFORE STARTING INSTALLATION	1
3. JOB NUMBER IDENTIFICATION	1
4. HANDING	2
5. 2 SECTION SLIDE-UP CAR DOOR ASSEMBLY	3
6. CAR DOOR & RETIRING CAM INSTALLATION NOTES	4
6.1. GENERAL	4
6.2. CAR DOOR RAILS & BRACES	4
6.3. CAR DOOR PANEL	5
6.4. CAR DOOR MOTORIZED SHEAVES OR MANUAL SPROCKETS & IDLER SPROCKETS	5
6.5. CAR DOOR COUNTERWEIGHT	5
6.6. CAR DOOR CHAINS AND CHAIN STUDS	5
6.7. CAR DOOR RUBBER BUMPERS	6
6.8. CAR DOOR CONTACT	6
6.9. RETIRING CAM	6
6.10. PULL STRAPS	7
7. CAB / CAR ENCLOSURE PREPARATION	8
8. RAIL INSTALLATION	9
9. RAIL SPREADER & DIAGONAL BRACE	10
10. GAUGE THE RAILS	11
11. SET THE RAILS	12
12. BRACING RAILS TO CAR	13
13. COUNTERWEIGHT PARTS ASSEMBLY	14
14. COUNTERWEIGHT INSTALLATION	15
15. IDLER / ENCODER INSTALLATION	18
16. OPERATOR / SPROCKET INSTALLATION	19
17. PANEL BUMPERS	20
18. UNLOADING THE PANELS	21
19. PANEL INSTALLATION	22
20. CHAIN CONNECTION DETAIL	23
21. PANEL ROPING (CHAIN INSTALLATION)	24
22. PANEL ROPING - SINGLE COUNTERWEIGHT	25
23. PANEL ROPING - DOUBLE COUNTERWEIGHT	26
24. REMOVE COUNTERWEIGHT STOP ANGLE	29
25. PULL STRAP INSTALLATION (MANUAL OPERATION)	30
26. CAR DOOR / CAR DOOR CONTACT	31
27. ENCODER - DOUBLE COUNTERWEIGHTS	32



THE PEELLE COMPANY

FREIGHT DOORS | CAR GATES | CAR ENCLOSURES

TECHNICAL SUPPORT 1-800-787-5020 ext 275

Guide No. 246-EN

2 SECTION SLIDE-UP CAR DOOR
INSTALLATION GUIDE

Date: May 15 / 2018

28. RETIRING CAM TOP ASSEMBLY.....	.33
29. RETIRING CAM BOTTOM ASSEMBLY.....	.34
30. RETIRING CAM ROD INSTALLATION.....	.35
31. FILLER ANGLES.....	.36
32. GOF MICRO SWITCH INSTALLATION.....	.37
33. CAR DOOR PROXIMITY SENSOR (OPTIONAL).....	.38
34. DOOR PROXIMITY SENSOR (OPTIONAL).....	.39



THE PEELLE COMPANY

FREIGHT DOORS | CAR GATES | CAR ENCLOSURES

TECHNICAL SUPPORT 1-800-787-5020 ext 275

Guide No. 246-EN

2 SECTION SLIDE-UP CAR DOOR
INSTALLATION GUIDE

Date: May 15 / 2018

1. FORWARD

The following Installation Guide is for a standard Peelle product assembly. However, Peelle products are designed-built to suit many elevator conditions such as very large openings, limited elevator shaft dimensions, hoistway conditions and unique lift designs. Therefore special designs, arrangements or add-ons may not be covered in this manual. Refer to the installation drawings provided with your order for instructions on special components or arrangements.

If you have any questions, concerns or require further details regarding your installation please call 1 (905) 846-4545 x 275, please have your Peelle Job Number handy. A Peelle technical support expert will help you save time and keep the installation moving.

2. BEFORE STARTING INSTALLATION

- 1) You will require a moving platform
- 2) This is a two person job
- 3) Safety Equipment
 - Personal Protective Equipment
 - Workplace Barricades
 - Fall Protection
- 4) Tools required
 - Measuring Tape
 - Level
 - High Speed Drill
 - Drill Bits HSS 5/16" [8mm] & 3/8" [10mm]
 - Impact Wrench
 - 9/16" [14mm] socket
 - Angle Grinder
 - Chain Pin Extractor (Chain Breaker) (Peelle Part No. 0608)
 - Open and closed ended wrenches (3/8" to 7/8") [10mm to 22mm]
 - Socket set (3/8" to 7/8") [10mm to 22mm]
 - Screwdriver Set
 - Pliers
- 5) Hardware kits included
 - Peelle Part No. 060133 - Standard car door hardware kit
 - Peelle Part No. 02321 - Counterweight shoe hardware

3. JOB NUMBER IDENTIFICATION

- Locate the peelle job number on the rails, car door panel and counterweight.
- Job numbers should match and include the line designation
- Example:

104844 GPA

104844 = Job Number
GP = Gate Panel
A = Front Line (C = Rear Line)



THE PEELLE COMPANY

FREIGHT DOORS | CAR GATES | CAR ENCLOSURES
TECHNICAL SUPPORT 1-800-787-5020 ext 275

1

Guide No. 246-EN

**2 SECTION SLIDE-UP CAR DOOR
INSTALLATION GUIDE**

Date: May 15 / 2018

4. HANDING

- Instructions shown here are typical for a car door with a Peelle right hand mounted interlock and retiring cam. For left hand installations opposite configuration will be used.

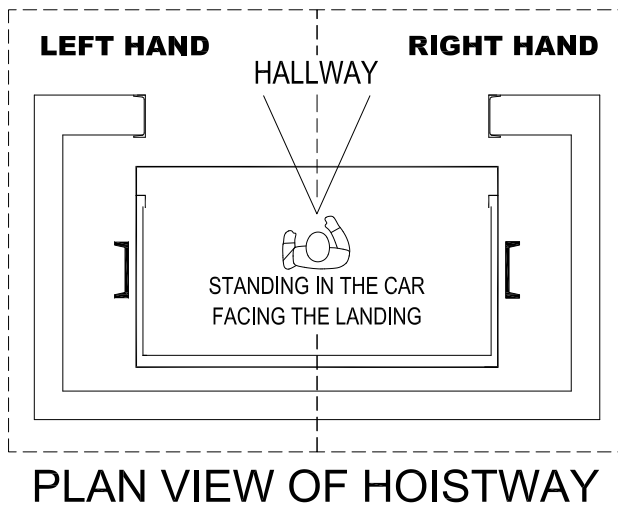

THE PEELLE COMPANY

FREIGHT DOORS | CAR GATES | CAR ENCLOSURES

TECHNICAL SUPPORT 1-800-787-5020 ext 275

2

Guide No. 246-EN

2 SECTION SLIDE-UP CAR DOOR
INSTALLATION GUIDE

Date: May 15 / 2018

5. 2 SECTION SLIDE-UP CAR DOOR ASSEMBLY

770071-35

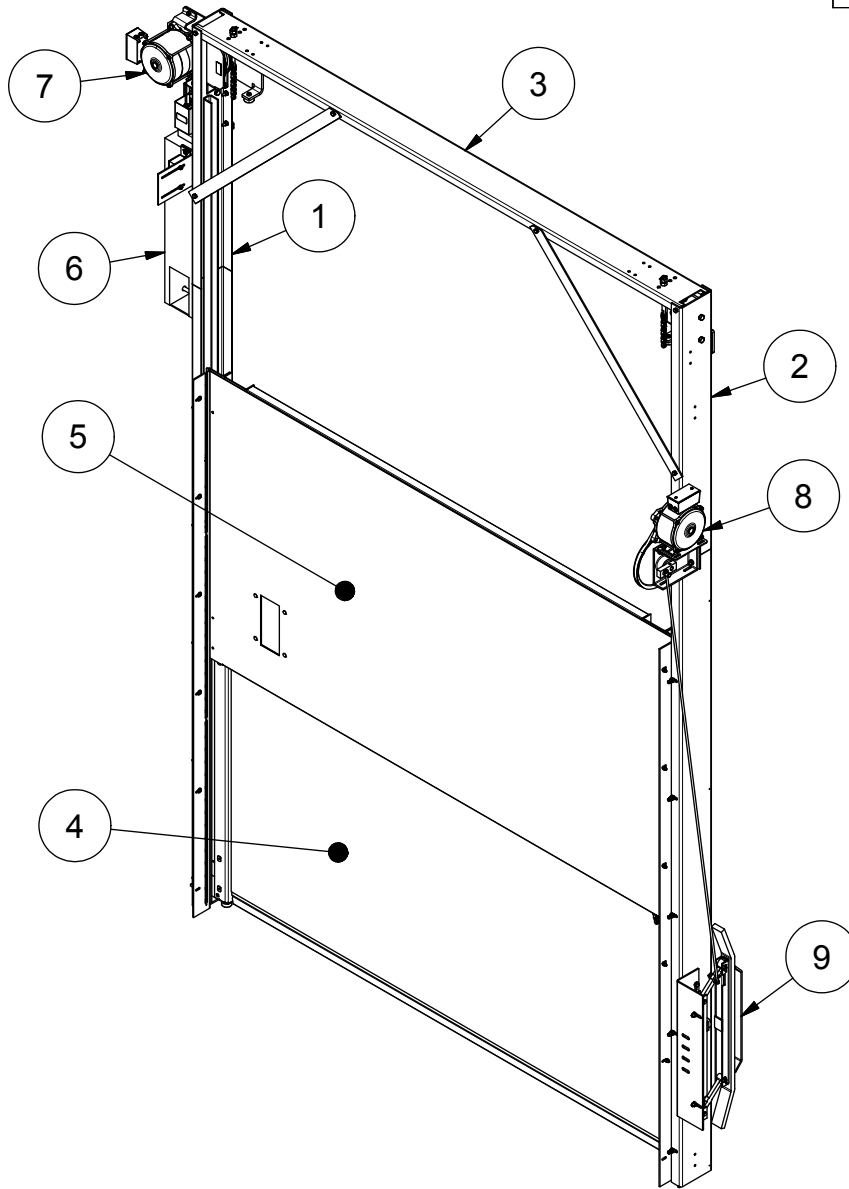

9	233087	RETIRING CAM BOTTOM ASSY
8	233065R	RETIRING CAM TOP ASSY
7	2547	OPERATOR
6	770082	COUNTERWEIGHT
5	770047	UPPER PANEL
4	770046	LOWER PANEL
3	770070	SPREADER
2	770068	RAIL, IDLER - LEFT HAND
1	770065	RAIL, COUNTERWEIGHT - RIGHT HAND
ITEM	PART NO	DESCRIPTION



THE PEELLE COMPANY

FREIGHT DOORS | CAR GATES | CAR ENCLOSURES

TECHNICAL SUPPORT 1-800-787-5020 ext 275

3

Guide No. 246-EN

2 SECTION SLIDE-UP CAR DOOR
INSTALLATION GUIDE

Date: May 15 / 2018

6. CAR DOOR & RETIRING CAM INSTALLATION NOTES

6.1. GENERAL

Install car doors after the landing doors are installed. Car doors are counterweighted with a counterweight traveling on the outside of the car door rails. Refer to the Car Door Assembly Drawing for a component breakdown. Where the overhead space is limited, the car door is made in two sections or three sections.

Overhead/headroom height is the area of a hoistway shaft extending up from the sill of the highest landing to the nearest obstruction above in the hoistway shaft. A two-section (telescopic) car door is used when over-head space will not allow a single section car door. The two sections of the car door are coupled, with the lower panel traveling twice as fast as the upper panel. This enables both sections to reach the open position simultaneously.

CAR DOOR TYPES (VERTICAL-SLIDE-UP TYPE):

- Single-section - available overhead space.
- Two-section (Telco) - limited overhead space.
- Three-section (Telco) - extremely limited overhead space

PANEL CONSTRUCTION

- Solid Panel
- Wire Mesh (option to save car weight)

If installing both a front car door and a rear car door, make sure they are installed at proper front or rear locations to allow the retiring cams to operate the door interlocks. Do not switch the front and rear car doors. The hands (LH & RH) of a retiring cam, car door counterweight and all hardware are as viewed from inside the car looking out. The retiring cam is on one side (either right or left hand) of the car door and the counterweight is on the other side (the other hand).

6.2. CAR DOOR RAILS & BRACES

Before installation of the rails, measure the distance from the front of the elevator platform to the car enclosure angles. If not enough space has been provided between the front of the platform and the car enclosure angles, it will be necessary to cut back the cab side walls and relocate the car enclosure angles. Be sure of your measurements before you do any cutting. The car enclosure angles are usually 50mm by 50mm by 5mm [2in x 2in x 3/16in] steel angles and should have holes to attach the car door rails.

Install the car door rails. Bolt them to the platform and to the car enclosure angles. Make sure the rails are plumb and square. Hold the correct distance-between-guides so the car door will fit. Use "Distance Between Guides" (DBG) dimension located on the Gauge Rod.

After installing both sets of car door rails, attach the top spreader, brace angle and diagonal brace. The top of the car door is held in place by two brace angles connected to the elevator cross-head. The distance between the car door rails must be constantly maintained when the spreader and braces are installed. Bolt braces tightly after car door panel is installed and adjusted.



THE PEELLE COMPANY

FREIGHT DOORS | CAR GATES | CAR ENCLOSURES

TECHNICAL SUPPORT 1-800-787-5020 ext 275

4

Guide No. 246-EN

**2 SECTION SLIDE-UP CAR DOOR
INSTALLATION GUIDE**

Date: May 15 / 2018

Check the overhead / headroom space for interference, then run the car up slowly on inspection to the top floor and check overhead / headroom for code clearance of car door rails and braces, and run by.

6.3. CAR DOOR PANEL

To install the car door panel, remove the shoes on either side, move the car door into its guide tracks while sliding on the platform. Then reinstall the shoes.

Install the upper panel first and hold in place using wood braces. Install the lower panel in the closed position on the car floor.

6.4. CAR DOOR MOTORIZED SHEAVES OR MANUAL SPROCKETS & IDLER SPROCKETS

Power car door operators have a combination sheave and motor while manual car doors have a double sprocket assembly that bolts into the pre-drilled rail location on the counterweight side. The single sprocket idler assembly is mounted inside the opposite rail.

6.5. CAR DOOR COUNTERWEIGHT

The counterweight travels on the outside of the car door rail. The counterweight requires two supporting chains. Carefully hoist the counterweight to the top of the car. Lower the counterweight into the guide track so that it rests on the temporary support angle near the top of the guide track.

If removed, attach the two counterweight guide shoes with hex-head thread-locker bolts provided. A hole through the rail is provided for bolting the shoe with a socket.

6.6. CAR DOOR CHAINS AND CHAIN STUDS

Attach the two counterweight chain-studs 100mm [4in] long to the counterweight. Attach the chains to the chain-studs, short chain to the front stud and long chain to the rear stud. Wrap connecting links and connector clips at each end of the chain with the nylon tie-wraps provided. Wipe any excess oil off the chains.

Loop the short chain over the front of the double sprocket. Loop the long chain over the rear of the double sprocket and then over the idler sprocket. Remove extra links from end of chain and connect the longer chain studs 180mm [7in]. long to the loose ends of the chains and then connect these chain studs into their hangers on the car door panel. Secure the master chain connecting links with nylon tie wraps. Each chain stud gets 2 nuts, a lock washer and a cotter pin. Make sure the nuts are almost touching the cotter pin near the bottom of the chain stud. This allows for the easy future chain stretch adjustment.

Connect the upper pane chain to the chain stud in the holes provided in the top spreader. Connect the other end of the chain around the upper panel sheave and to the lower panel chain pickup.

After attaching the chains to both the counterweight and car door panel, remove the temporary support angle. Manually lift the car door to full open. Have it touch the upper bumper stops. At this position, the bottom edge of the car door should be even with or slightly above the car enclosure ceiling. If the car door was not fully open due to the counterweight bottoming out, the chains are



THE PEELLE COMPANY

FREIGHT DOORS | CAR GATES | CAR ENCLOSURES

TECHNICAL SUPPORT 1-800-787-5020 ext 275

5

Guide No. 246-EN

**2 SECTION SLIDE-UP CAR DOOR
INSTALLATION GUIDE**

Date: May 15 / 2018

too long and must be adjusted at the studs or some links must be removed to shorten the chains.

Finally adjust the chain studs with just slightly more tension (less slack) on the long chain to allow for greater chain stretch. The car door must move smoothly in the guide rails during its entire travel. Adjust the shoes (inward-outward) only if the car door panel is not square in the guide rails or if there is no side-to-side play. With the car door raised 75mm [3in] off the platform, check to see if car door panel hangs level. Adjust the chains to level the car door panel.

The car door panel should balance the counterweight at half-travel position. With the car door at half-travel open, manually push it further open and from the same position push it closed. Weight differential can usually be detected by this method. Add or remove the counterweight flats to achieve balance of the counterweight and the car door panel.

The car door panel must be exactly balanced (at half-travel position) by the counterweight to prevent the car door drifting open when the elevator car is in motion or from drifting closed at an inappropriate time.

6.7. CAR DOOR RUBBER BUMPERS

Bumpers are important to reduce noise and reduce car door wear and tear. The car door bottom bumpers can be adjusted by adding flat washers as spacers for proper positioning if the car platform is not level.

6.8. CAR DOOR CONTACT

When the car door is in the closed position the electrical car door contact must also be “made”. This is activated by a roller cam attached to the top of the car door counterweight. The counterweight has a small degree of horizontal play. Ensure the car door contact will remain “made” by moving the counterweight back and forth.

Check that the car door contact stops the elevator when the car door is lifted up 50mm [2in] from its closed position. If there are two car doors on an elevator, the car door contacts usually wired in series. See elevator controller prints.

6.9. RETIRING CAM

Freight door interlocks are designed to be operated by a retiring cam. The retiring cam is mounted on the car. There is a connecting rod between the cam face and the retiring cam motor.

The cam motor is mounted above the car top height. The cam face assembly is mounted on the side of the car, vertically near the door opening centerline for biparting doors and lower down for slip up landing doors. Both have pre-drilled holes in the Peelle car door rail. Follow the installation drawings when you are installing the retiring cam. The retiring cam face should be mounted to the center of the interlock rollers horizontally and vertically when the car is at each floor. The interlock rollers must be adjusted so that when the cam is extended (by gravity), it unlocks the interlock. The cam must be set to fully unlock the interlock with over-travel.

The cam face is weighted so that the cam will drop while in the “no power” condition and unlock



THE PEELLE COMPANY

FREIGHT DOORS | CAR GATES | CAR ENCLOSURES

TECHNICAL SUPPORT 1-800-787-5020 ext 275

6

Guide No. 246-EN

**2 SECTION SLIDE-UP CAR DOOR
INSTALLATION GUIDE**

Date: May 15 / 2018

the door. The doors can be manually opened if the car is at a landing and there is no power to the retiring cam. When the cam motor is energized, it lifts (retires) the cam face to allow the interlock to lock the door.

The cam large pulley should be operated by hand to make sure that it does not bind or hang-up. The V-belt deflection should be set at 13mm [1/2in]. Adjust the motor position to achieve 13mm [1/2in] deflection.

The effective length of the connecting rod between the crank pulley and the cam face must be adjusted so that the rotation of the crank is limited. To adjust the cam rod length: manually hold the cam face fully up (retired); while held in this position, rotate the crank arm towards the center of the car; tighten the rod nuts with the crank held 90 degrees back (towards the center of the car) from the down direction. When powered the cam motor must then pick the cam rod toward the center of the car. If the direction of the lift is toward the front of the car, reverse the motor rotation by switching any two of the three motor power leads. The cam rod must pick toward the center of the car. The motor must pick up and stall when the cam is retired (picked up) under power. The cam face must drop easily when not under power.

Fixed cams are sometimes used instead of retiring cams with side-opposite-locks. Mechanical door locking must take place as the car travels away from the floor.

After installing the cam(s), run the car up slowly on inspection to check any retiring cam obstacles in the hoistway shaft.

6.10. PULL STRAPS

Pull strap(s) may be provided for each door and car door. Pull straps are mounted on the panel and hang down so that the operator may pull the car doors closed. Limiting the length of the straps ensures that they do not become a hazard during operation of the car.

DO NOT TIE KNOTS IN STRAPS OR CREATE LOOPS

Straps are required for manually operated vertically sliding car doors to ensure they can be conveniently closed. Car doors require one pull strap and biparting doors require two straps.

If supplied on power operated car doors, the straps will be tucked away behind a clip, and still be accessible in case of a power failure. Where pull straps have been provided on car doors conforming to ASME A17.1/CSA B44, 2008 addenda, a pull strap contact is provided and should be wired in series with door stop button contact to the Peelle door controller.



THE PEELLE COMPANY

FREIGHT DOORS | CAR GATES | CAR ENCLOSURES

TECHNICAL SUPPORT 1-800-787-5020 ext 275

7

Guide No. 246-EN

**2 SECTION SLIDE-UP CAR DOOR
INSTALLATION GUIDE**

Date: May 15 / 2018

7. CAB / CAR ENCLOSURE PREPARATION

770071-01

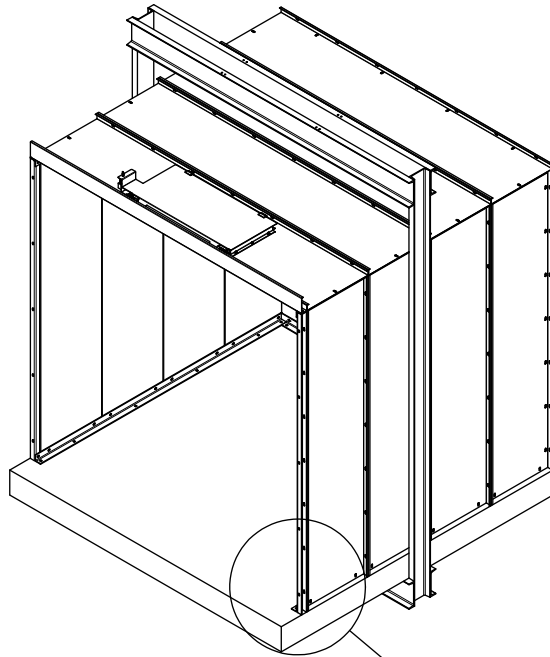

Refer to Layout Drawing (L-1) for further details regarding the car enclosure interface requirements.

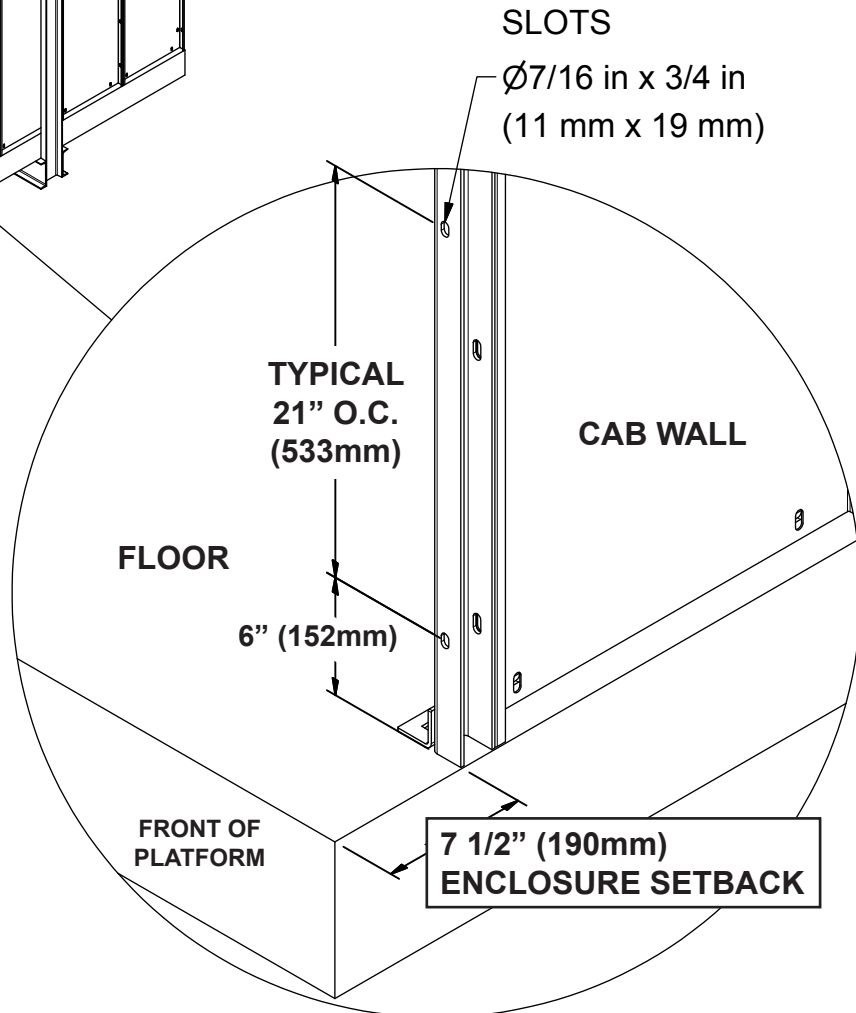

THE PEELLE COMPANY

FREIGHT DOORS | CAR GATES | CAR ENCLOSURES

TECHNICAL SUPPORT 1-800-787-5020 ext 275

8

Guide No. 246-EN

2 SECTION SLIDE-UP CAR DOOR
INSTALLATION GUIDE

Date: May 15 / 2018

8. RAIL INSTALLATION

770071-02

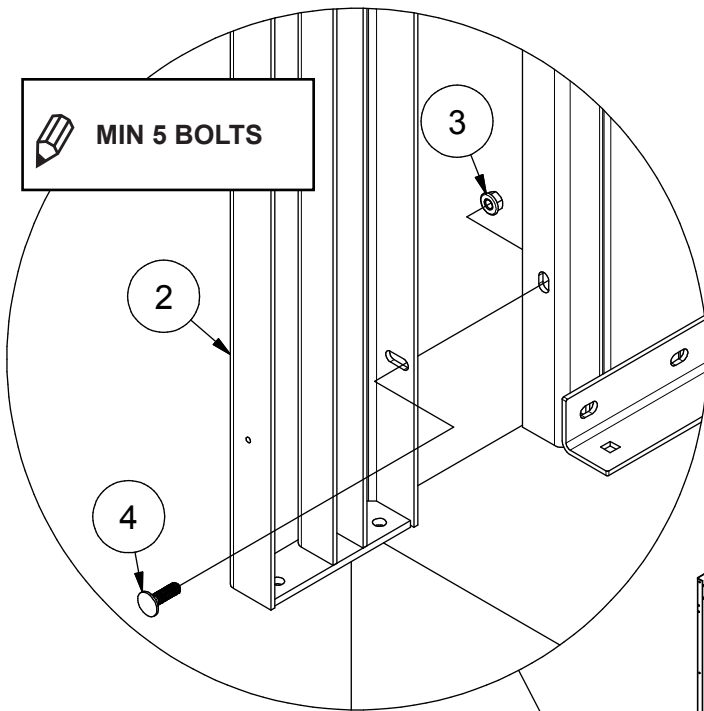

TYPICAL EACH SIDE

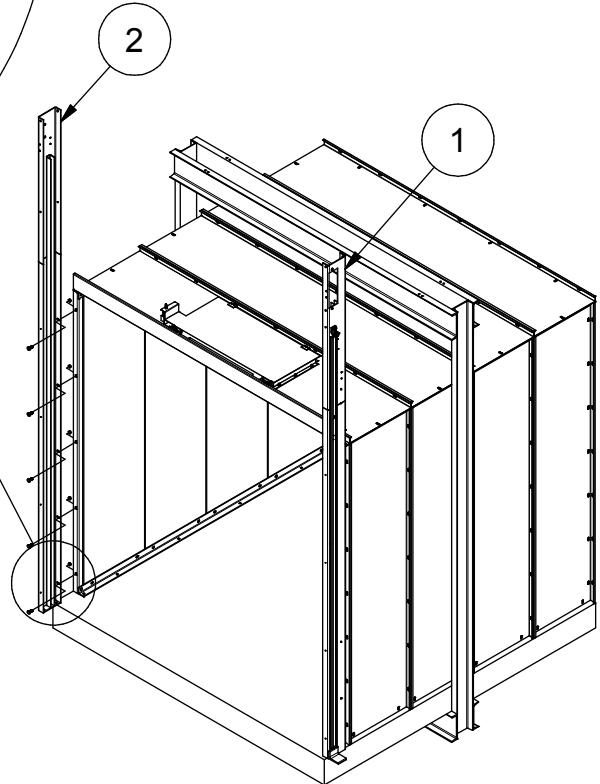

4	10	1121357	3/8"-16 x 1 1/4" Lg CARRIAGE BOLT ZP
3	10	97244	3/8-16 SERRATED FLANGE NUT Z
2	1	770068	RAIL, IDLER - LEFT HAND
1	1	770065	RAIL, COUNTERWEIGHT - RIGHT HAND
ITEM	QTY	PART NO	DESCRIPTION



THE PEELLE COMPANY

FREIGHT DOORS | CAR GATES | CAR ENCLOSURES
TECHNICAL SUPPORT 1-800-787-5020 ext 275

Guide No. 246-EN

2 SECTION SLIDE-UP CAR DOOR
 INSTALLATION GUIDE

Date: May 15 / 2018

9. RAIL SPREADER & DIAGONAL BRACE

770071-04

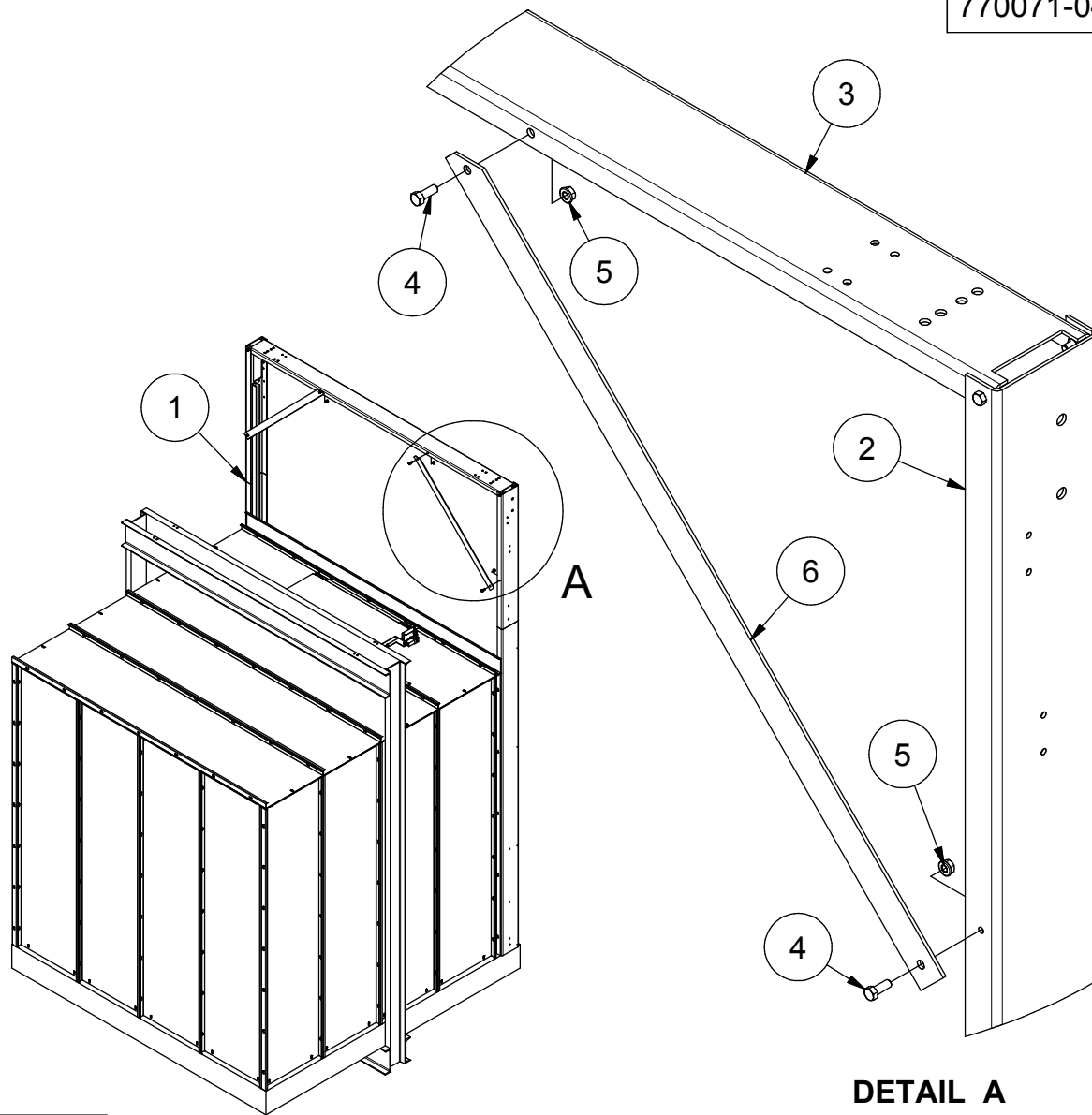

DETAIL A
TYPICAL EACH SIDE



6	2	066930	DIAGONAL BRACE
5	4	97244	3/8-16 SERRATED FLANGE NUT Z
4	4	800061	3/8-16 x 1 HH BOLT ZP
3	1	770070	SPREADER
2	1	770068	RAIL, IDLER - LEFT HAND
1	1	770065	RAIL, COUNTERWEIGHT - RIGHT HAND
ITEM	QTY	PART NO	DESCRIPTION



THE PEELLE COMPANY

FREIGHT DOORS | CAR GATES | CAR ENCLOSURES
TECHNICAL SUPPORT 1-800-787-5020 ext 275

10

Guide No. 246-EN

2 SECTION SLIDE-UP CAR DOOR
 INSTALLATION GUIDE

Date: May 15 / 2018

10. GAUGE THE RAILS

770071-05

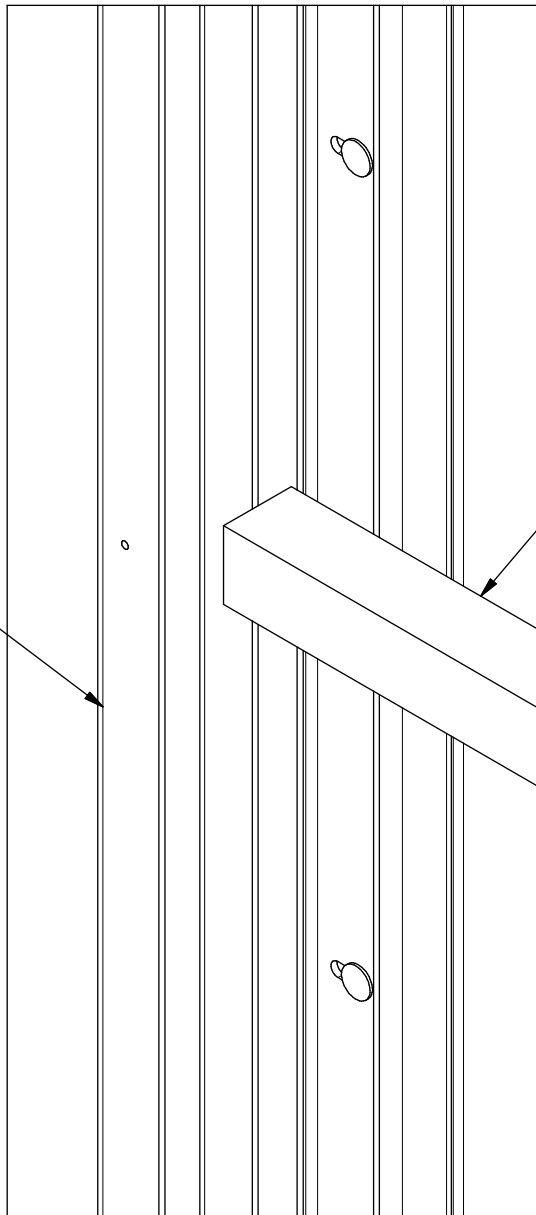

Gauge rails using gauge rod supplied. Adjust and tighten rails. Pin and set rails top and bottom.



HINT: After installation gauge rod can be used for additional rail support.

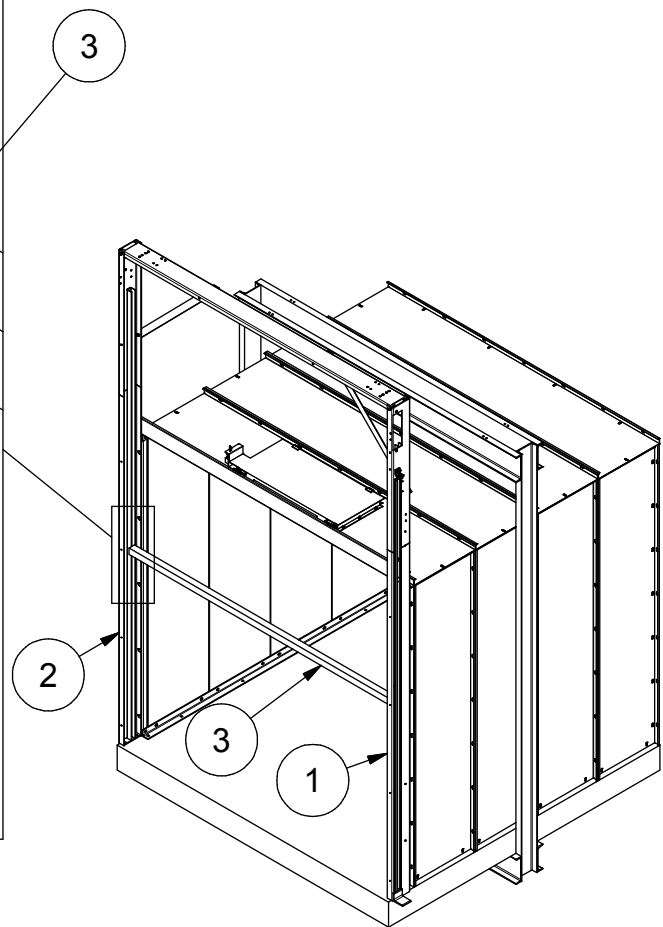

3	1		GAUGE ROD (50 mm [2 in] ANGLE)
2	1	770068	RAIL, IDLER - LEFT HAND
1	1	770065	RAIL, COUNTERWEIGHT - RIGHT HAND
ITEM	QTY	PART NO	DESCRIPTION



THE PEELLE COMPANY

FREIGHT DOORS | CAR GATES | CAR ENCLOSURES
TECHNICAL SUPPORT 1-800-787-5020 ext 275

11

Guide No. 246-EN

2 SECTION SLIDE-UP CAR DOOR
 INSTALLATION GUIDE

Date: May 15 / 2018

11. SET THE RAILS

770071-06

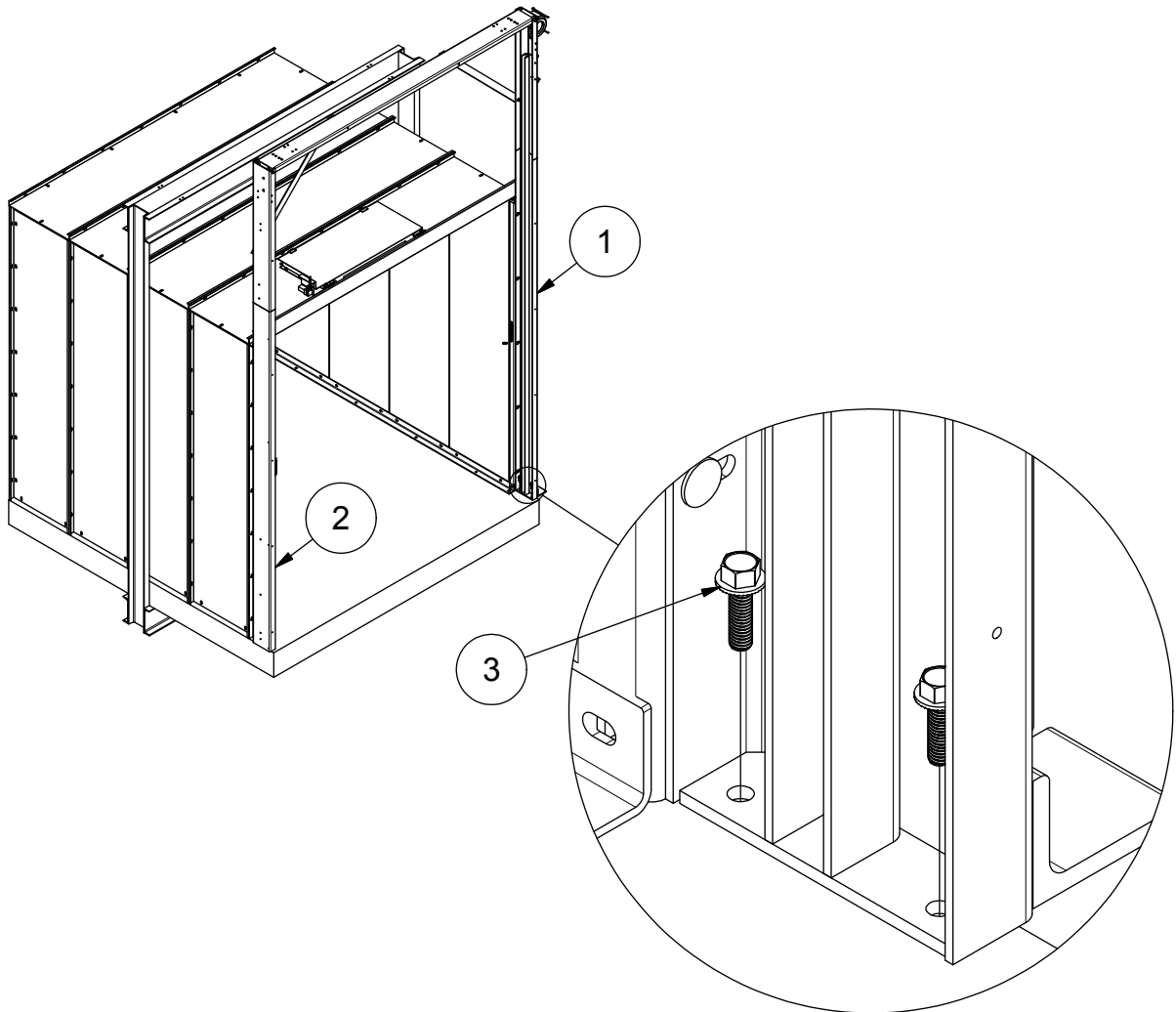

G2
HARDWARE
BAG

 Drill 9mm [5/16 in] diameter hole. Ensure hole is at least 30mm [1 1/4 in] deep.

ITEM	QTY	PART NO	DESCRIPTION
3	4	060004	3/8"-16 x 1 1/8" Lg FLANGED SELF TAPPING HEX HD BOLT ZP
2	1	770068	RAIL, IDLER - LEFT HAND
1	1	770065	RAIL, COUNTERWEIGHT - RIGHT HAND



THE PELLE COMPANY
FREIGHT DOORS | CAR GATES | CAR ENCLOSURES
TECHNICAL SUPPORT 1-800-787-5020 ext 275

12. BRACING RAILS TO CAR

770071-07

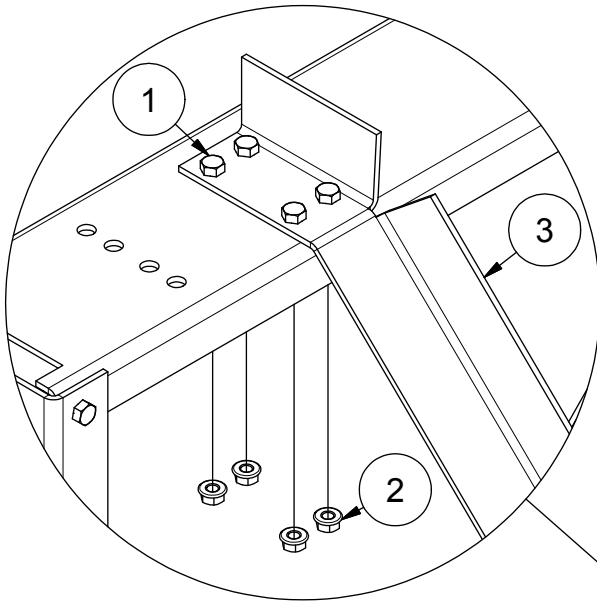

 Drill and bolt Brace Angles to car door rails spreader and cross head.

 Cut and notch one end of Brace Angle to suit.

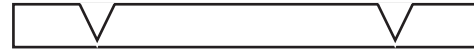

 Use Gauge Rod for additional support of needed.

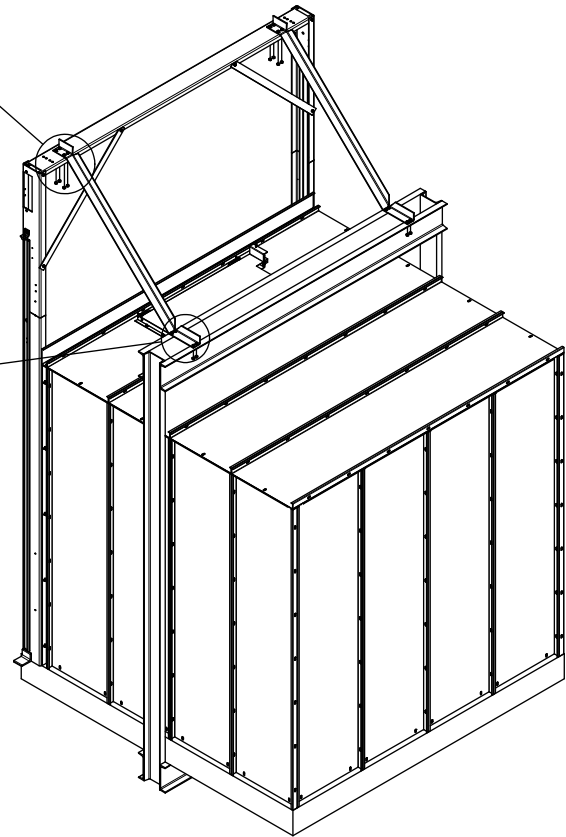
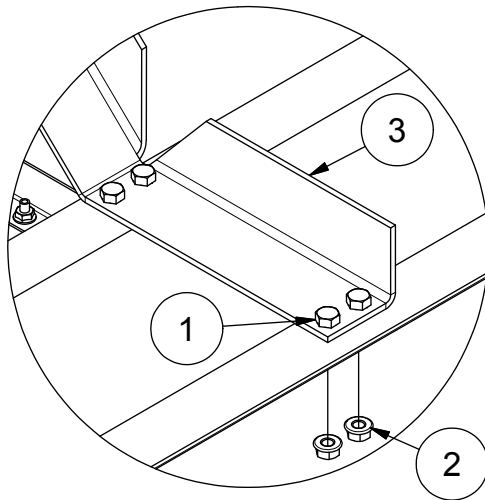

ITEM	QTY	PART NO	DESCRIPTION
3	2	770413	BRACE ANGLE
2	16	97244	3/8-16 SERRATED FLANGE NUT Z
1	16	800061	3/8-16 x 1 HH BOLT ZP



THE PEELLE COMPANY

FREIGHT DOORS | CAR GATES | CAR ENCLOSURES

TECHNICAL SUPPORT 1-800-787-5020 ext 275

13

Guide No. 246-EN

2 SECTION SLIDE-UP CAR DOOR
INSTALLATION GUIDE

Date: May 15 / 2018

13. COUNTERWEIGHT PARTS ASSEMBLY

770071-08



Prepare the counterweight for insertion into the rail



If your installation requires two counterweights, you will need to repeat the following steps, for each counterweight and side of the car door.

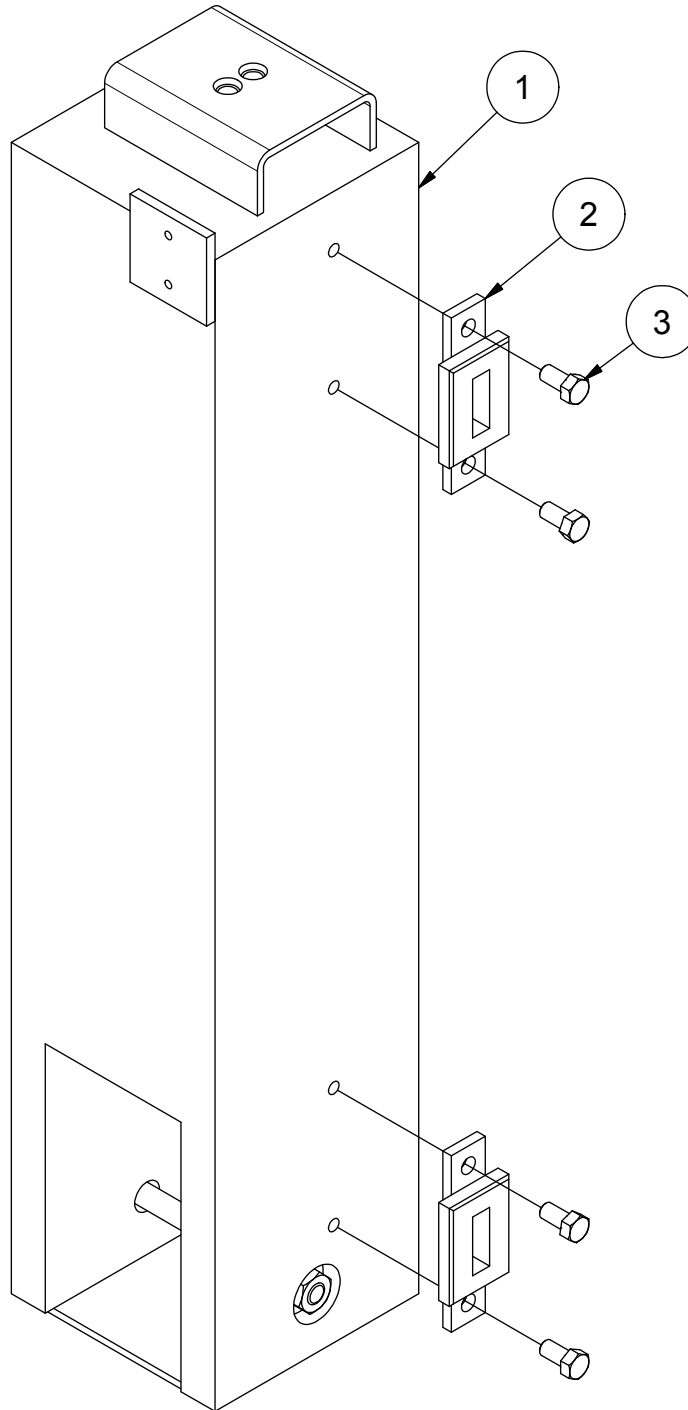

02321
HARDWARE BAG

3	4	02325	3/8"-16 x 3/4" Lg NYLOCK HEX HD BOLT ZP
2	2	0232	COUNTERWEIGHT GUIDE SHOE
1	1	770082	COUNTERWEIGHT
ITEM	QTY	PART NO	DESCRIPTION



THE PELLE COMPANY

FREIGHT DOORS | CAR GATES | CAR ENCLOSURES

TECHNICAL SUPPORT 1-800-787-5020 ext 275

14

Guide No. 246-EN

2 SECTION SLIDE-UP CAR DOOR
INSTALLATION GUIDE

Date: May 15 / 2018

14. COUNTERWEIGHT INSTALLATION

STEP 1

770071-10

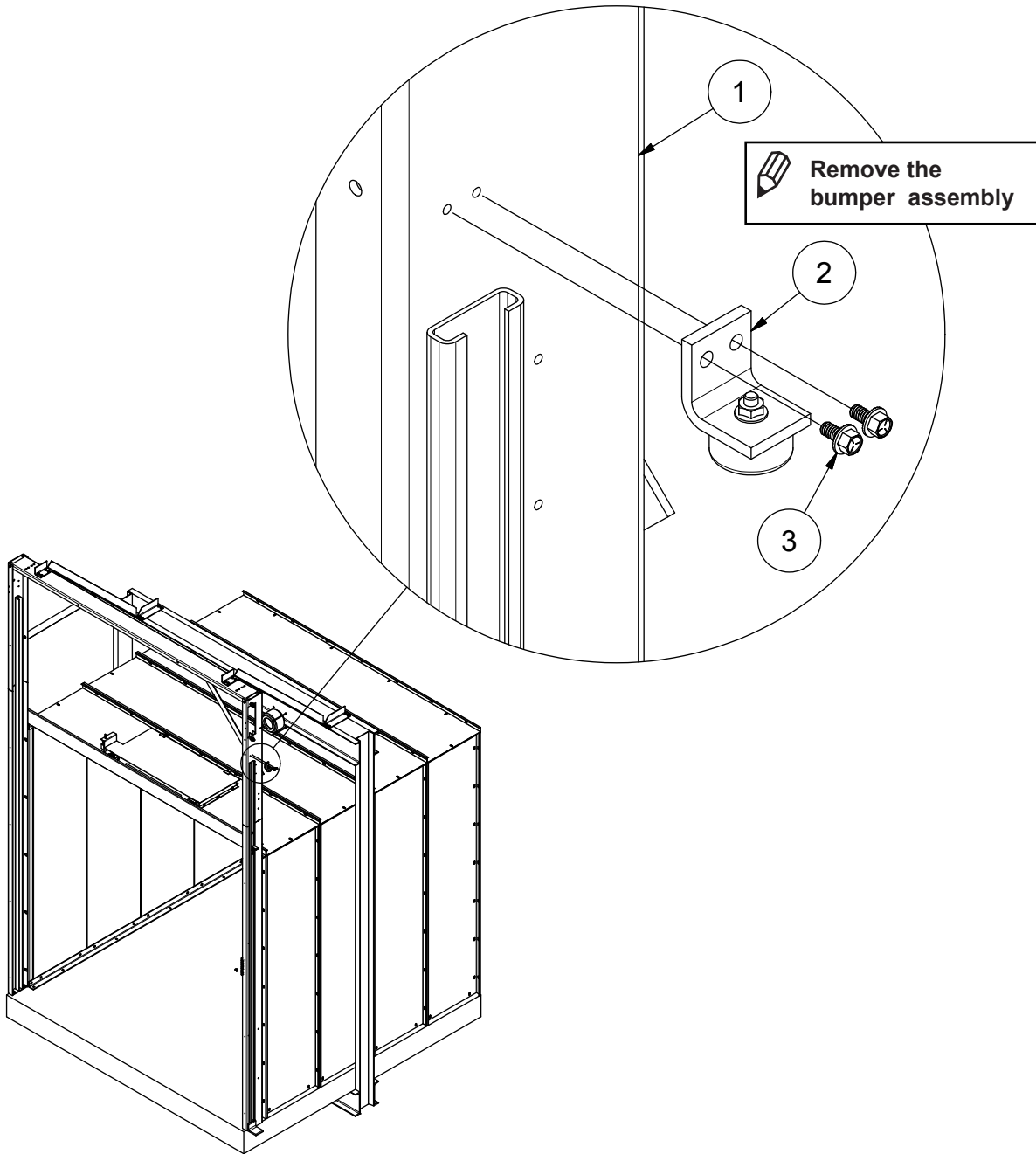

3	2	1119901	1/4-20 x 1/2 HEX HD FLANGE BOLT ZP
2	1	066848	BUMPER ASSY
1	1	770065	RAIL, COUNTERWEIGHT - RIGHT HAND
ITEM	QTY	PART NO	DESCRIPTION



THE PEELLE COMPANY

FREIGHT DOORS | CAR GATES | CAR ENCLOSURES
TECHNICAL SUPPORT 1-800-787-5020 ext 275

15

Guide No. 246-EN

2 SECTION SLIDE-UP CAR DOOR
 INSTALLATION GUIDE

Date: May 15 / 2018

STEP 2

770071-11

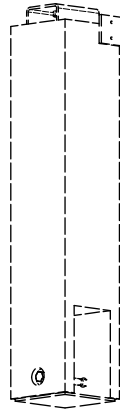

 Hoist counterweight up and down into track.

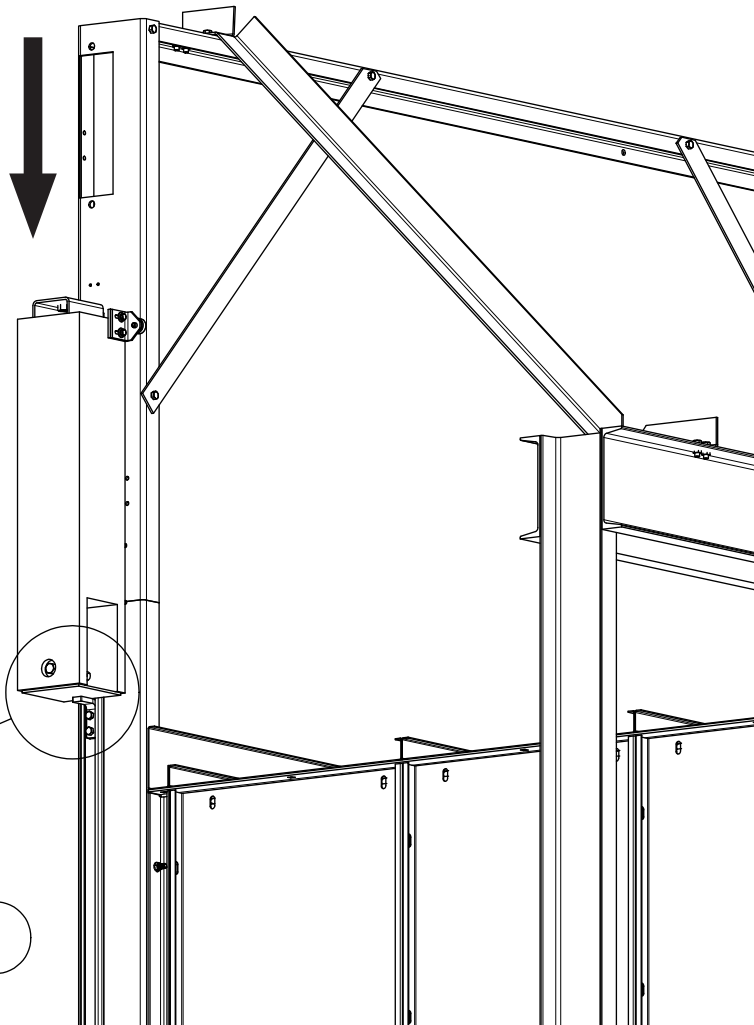

 Lower the counterweight down into the guide track rail onto the CWT Angle Stop

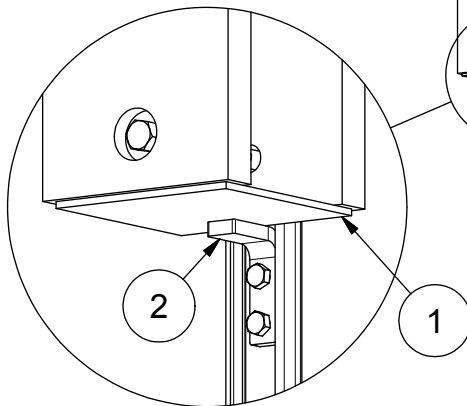

2	1	066935	COUNTERWEIGHT ANGLE STOP
1	1	770082	COUNTERWEIGHT
ITEM	QTY	PART NO	DESCRIPTION



THE PEELLE COMPANY

FREIGHT DOORS | CAR GATES | CAR ENCLOSURES

TECHNICAL SUPPORT 1-800-787-5020 ext 275

16

Guide No. 246-EN

2 SECTION SLIDE-UP CAR DOOR
INSTALLATION GUIDE

Date: May 15 / 2018

STEP 3

770071-12

 Re-attach the bumper assembly.

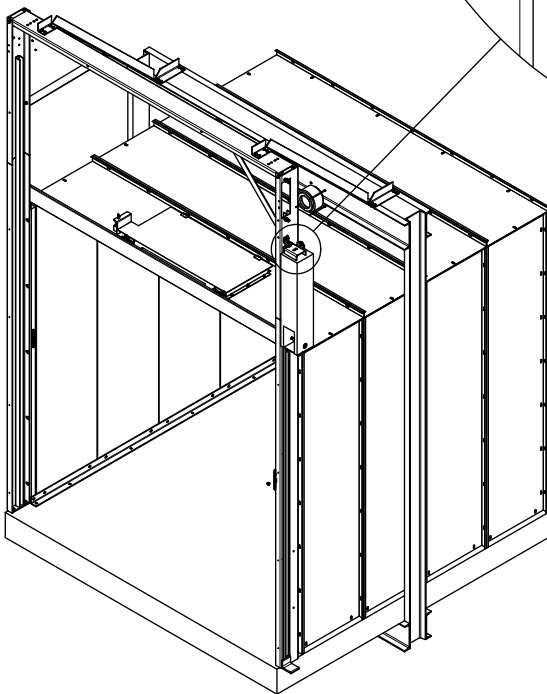
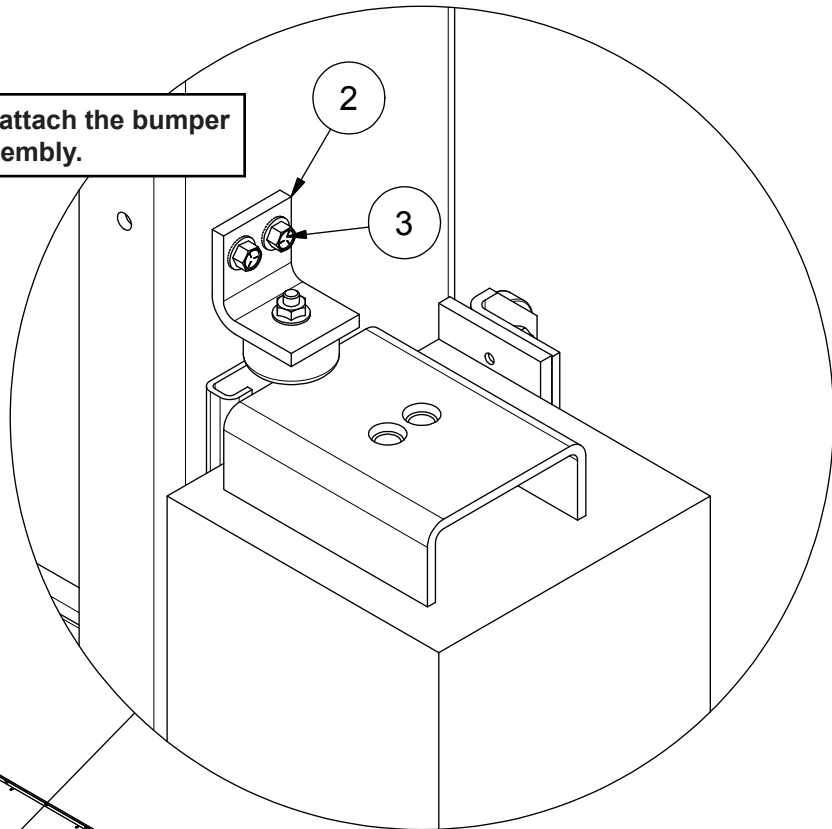

3	2	1119901	1/4-20 x 1/2 HEX HD FLANGE BOLT ZP
2	1	066848	BUMPER ASSY
ITEM	QTY	PART NO	DESCRIPTION



THE PEELLE COMPANY

FREIGHT DOORS | CAR GATES | CAR ENCLOSURES
TECHNICAL SUPPORT 1-800-787-5020 ext 275

17

Guide No. 246-EN

2 SECTION SLIDE-UP CAR DOOR
 INSTALLATION GUIDE

Date: May 15 / 2018

15. IDLER / ENCODER INSTALLATION

770071-13

 Spreader removed for clarity.

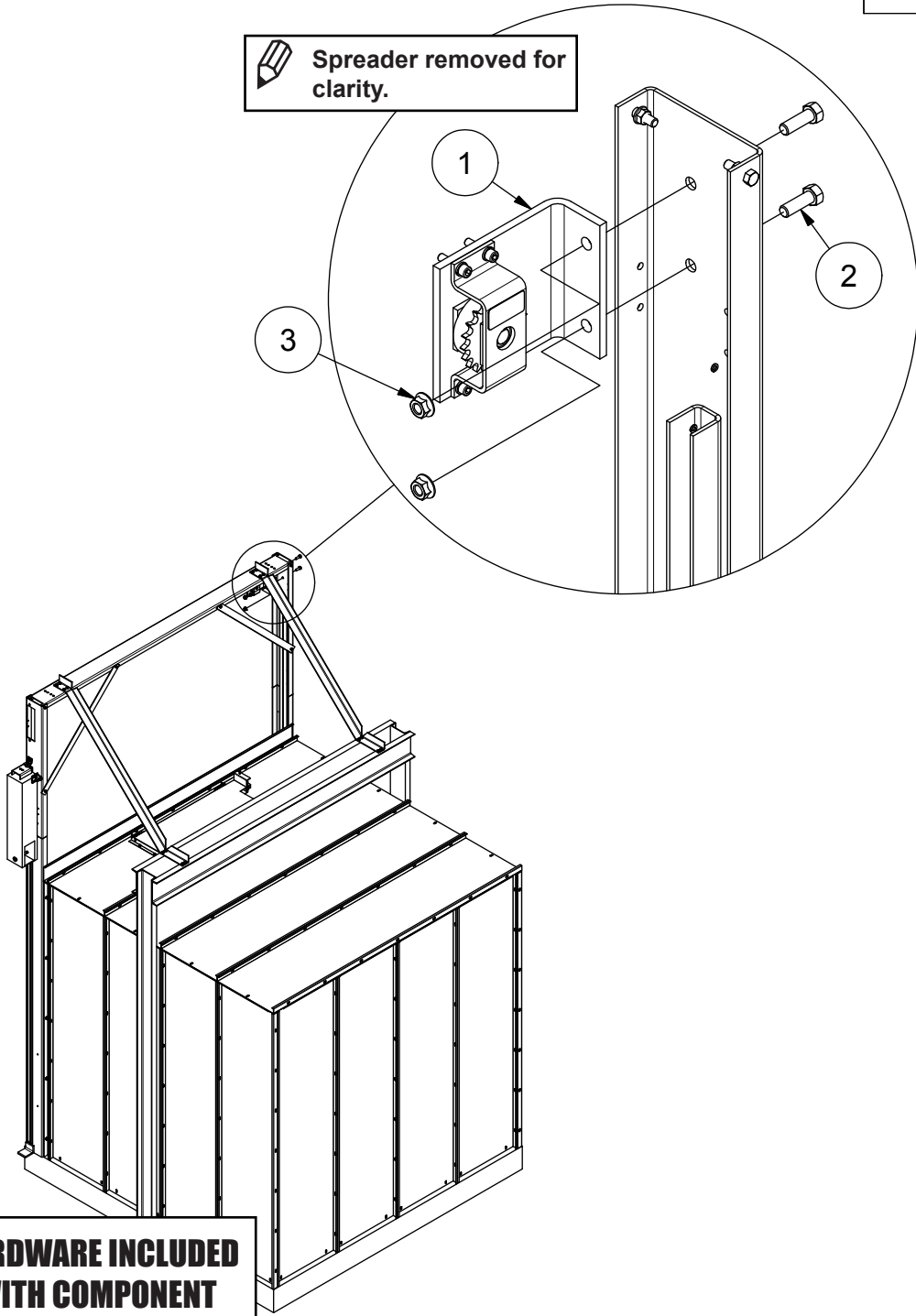

HARDWARE INCLUDED WITH COMPONENT

3	2	1137345	1/2-13 HEX SERRATED FLANGE NUT
2	2	110120380	1/2"-13 x 1 1/2" Lg HEX HD BOLT Z
1	1	2575	GATE IDLER ASSEMBLY
ITEM	QTY	PART NO	DESCRIPTION



THE PEELLE COMPANY

FREIGHT DOORS | CAR GATES | CAR ENCLOSURES
TECHNICAL SUPPORT 1-800-787-5020 ext 275

Guide No. 246-EN

2 SECTION SLIDE-UP CAR DOOR
 INSTALLATION GUIDE

Date: May 15 / 2018

16. OPERATOR / SPROCKET INSTALLATION

770071-17

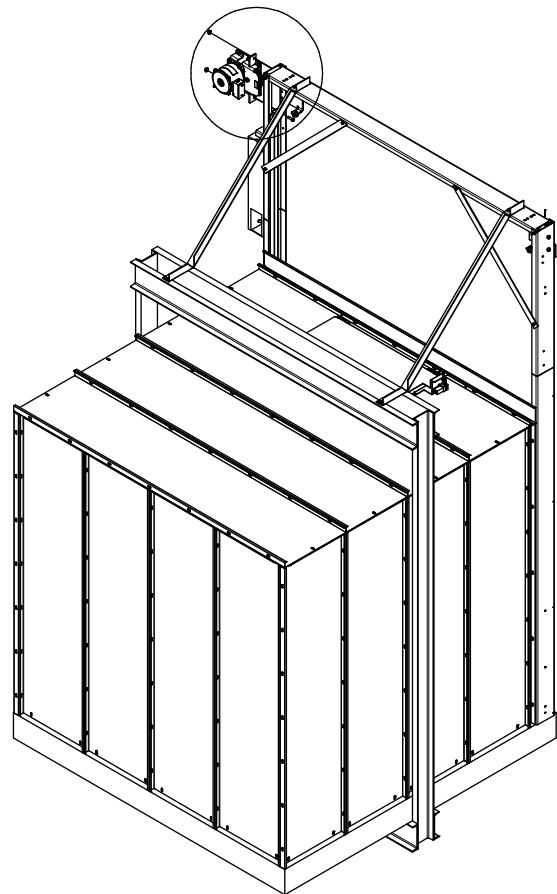
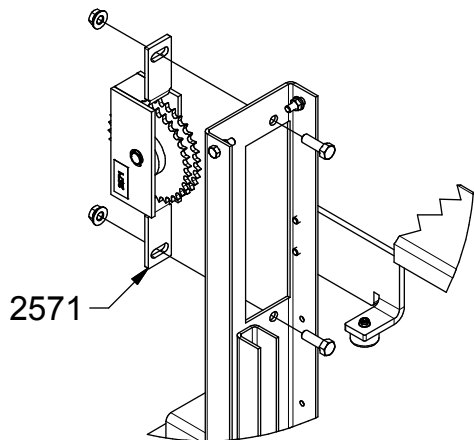
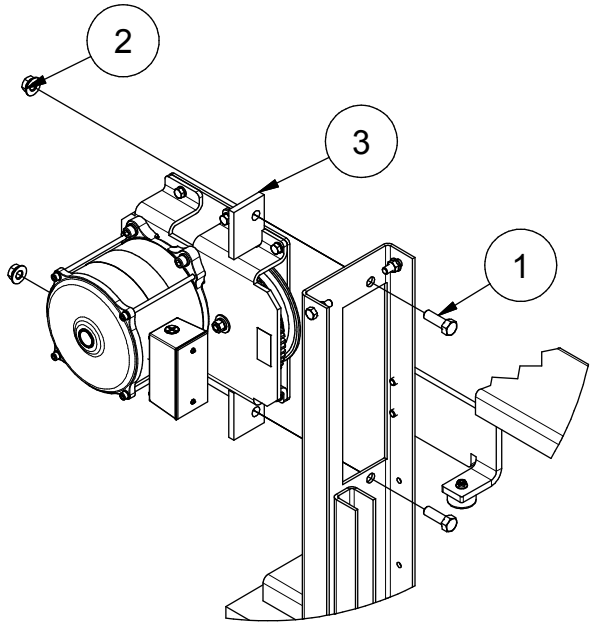

HARDWARE INCLUDED WITH COMPONENT

3	1	2525	GATE OPERATOR
2	2	1137345	1/2-13 HEX SERRATED FLANGE NUT
1	2	110120380	1/2"-13 x 1 1/2" Lg HEX HD BOLT Z
ITEM	QTY	PART NO	DESCRIPTION



THE PELLE COMPANY

FREIGHT DOORS | CAR GATES | CAR ENCLOSURES
 TECHNICAL SUPPORT 1-800-787-5020 ext 275

Guide No. 246-EN

2 SECTION SLIDE-UP CAR DOOR
 INSTALLATION GUIDE

Date: May 15 / 2018

17. PANEL BUMPERS

770071-16

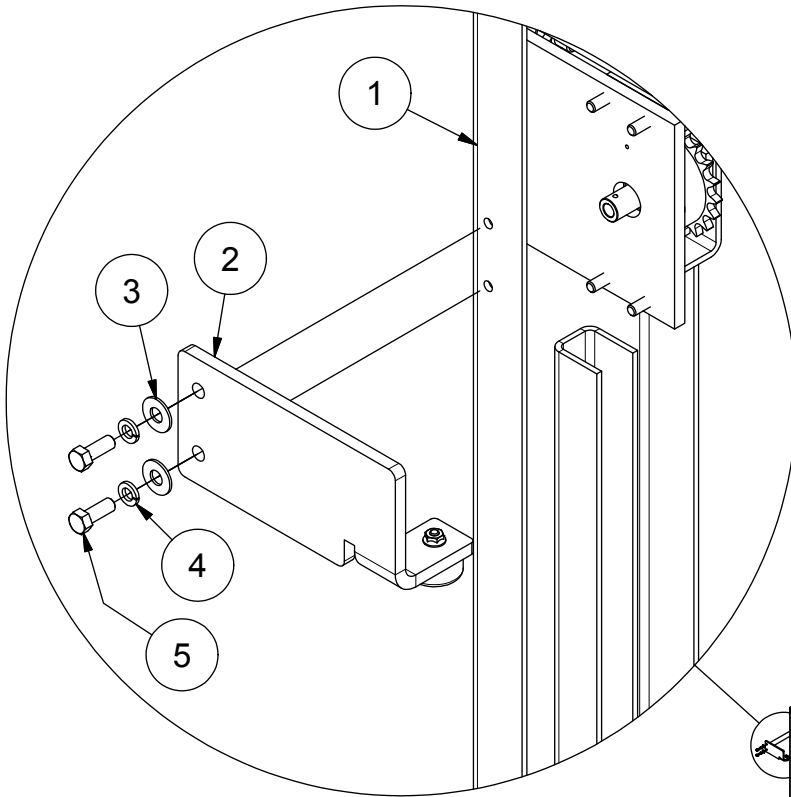

TYPICAL EACH SIDE

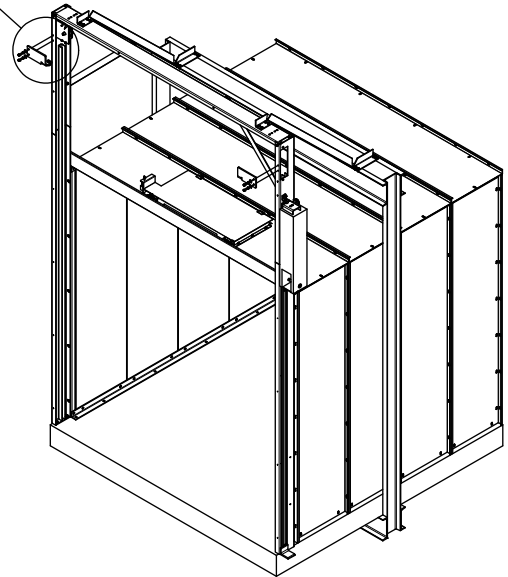

**HARDWARE INCLUDED
WITH COMPONENT**

5	4	800061	3/8-16 x 1 HH BOLT ZP
4	4	1133622	3/8" LOCK WASHER Z
3	4	1133008	3/8" FLAT WASHER Z
2	1	770076	CAR GATE BUMPER
1	1	770068	RAIL, IDLER - LEFT HAND
ITEM	QTY	PART NO	DESCRIPTION



THE PEELLE COMPANY

FREIGHT DOORS | CAR GATES | CAR ENCLOSURES
TECHNICAL SUPPORT 1-800-787-5020 ext 275

20

Guide No. 246-EN

2 SECTION SLIDE-UP CAR DOOR
INSTALLATION GUIDE

Date: May 15 / 2018

18. UNLOADING THE PANELS

Unload panels from pallets as shown to reduce the risk of bending and distorting the panels.

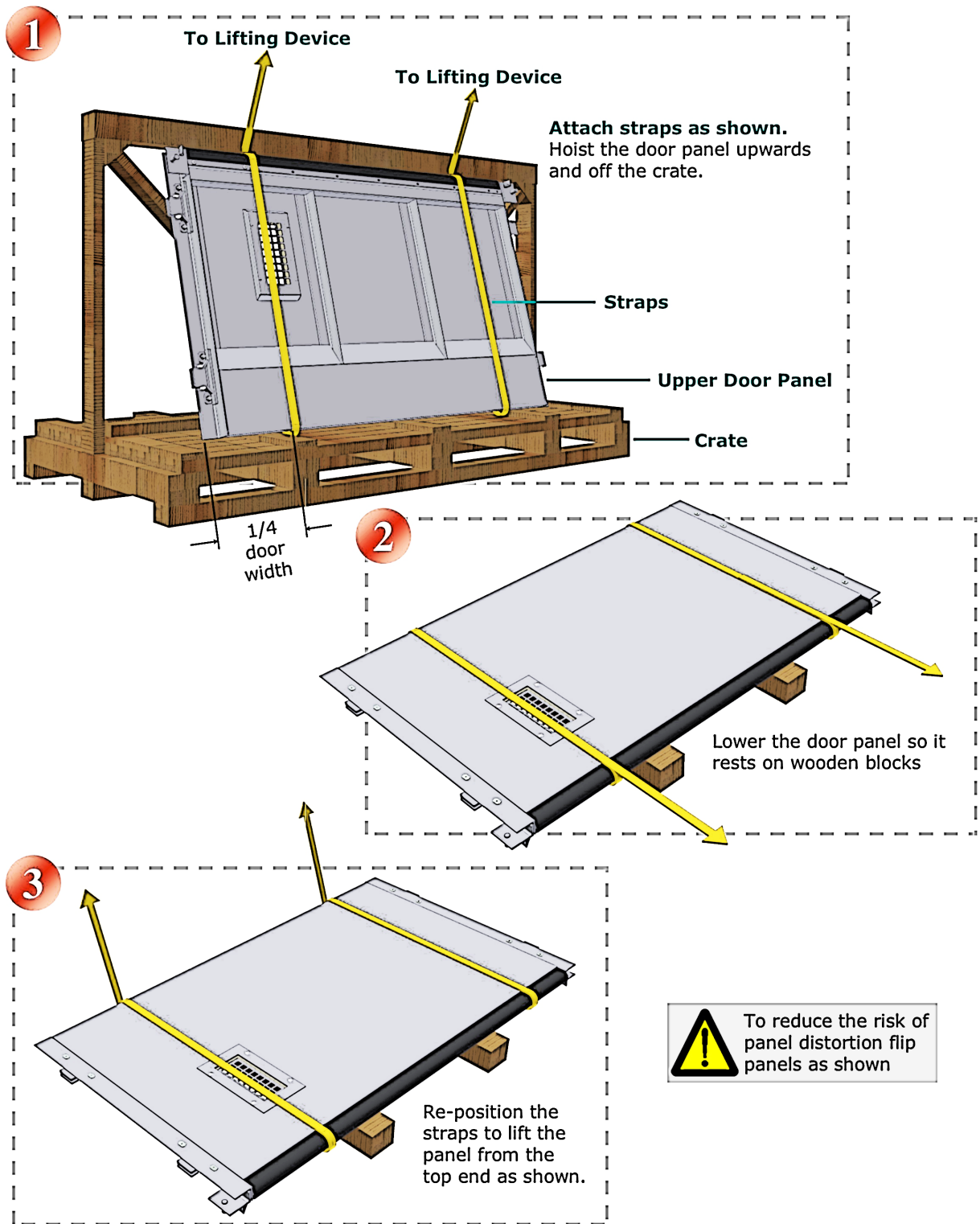

THE PELLE COMPANY

FREIGHT DOORS | CAR GATES | CAR ENCLOSURES

TECHNICAL SUPPORT 1-800-787-5020 ext 275

21

Guide No. 246-EN

2 SECTION SLIDE-UP CAR DOOR
INSTALLATION GUIDE

Date: May 15 / 2018

19. PANEL INSTALLATION



Install upper panel first.



TIP - when reattaching shoes, attach bottom shoe first.



Re-Attach Guide Shoe

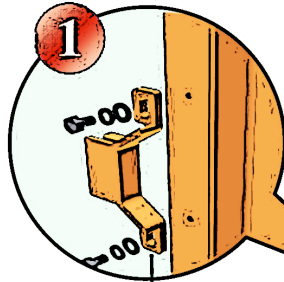

1 Remove guide shoes from one side of the upper panel, this allows you to fit the panel between the rails.

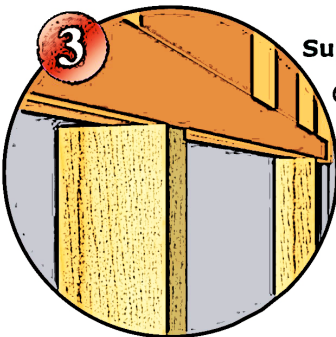
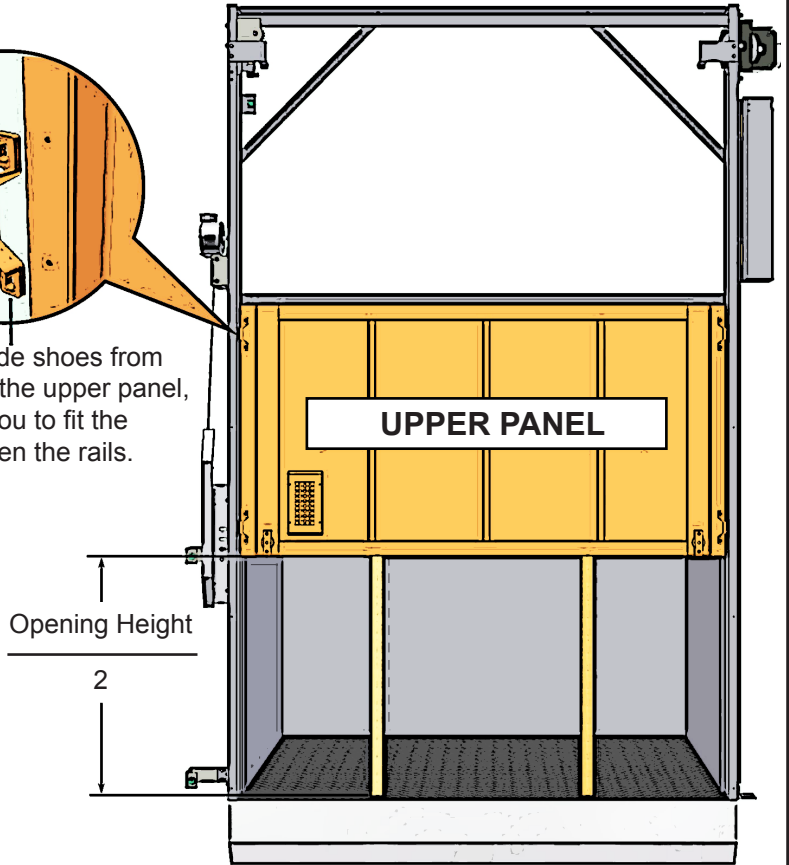

3 **Support Blocks**
Cut wood blocks to support the upper panel. Hoist up the upper panel

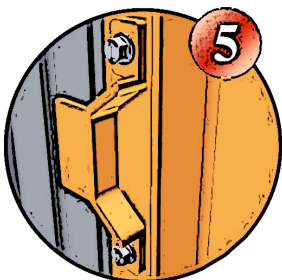

Re-Attach Guide Shoe

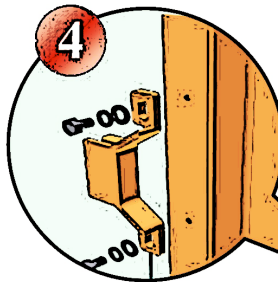

4 Remove guide shoes from one side of the lower panel.

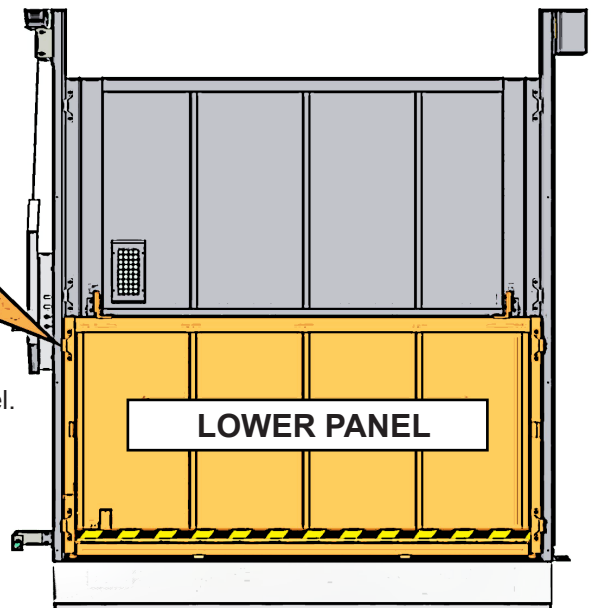

THE PELLE COMPANY

FREIGHT DOORS | CAR GATES | CAR ENCLOSURES
TECHNICAL SUPPORT 1-800-787-5020 ext 275

20. CHAIN CONNECTION DETAIL

770071-36



To remove links you will need to grind off the head of the pin. Then use the Peelle #0608 Chain Pin Extractor to pop out the pin.

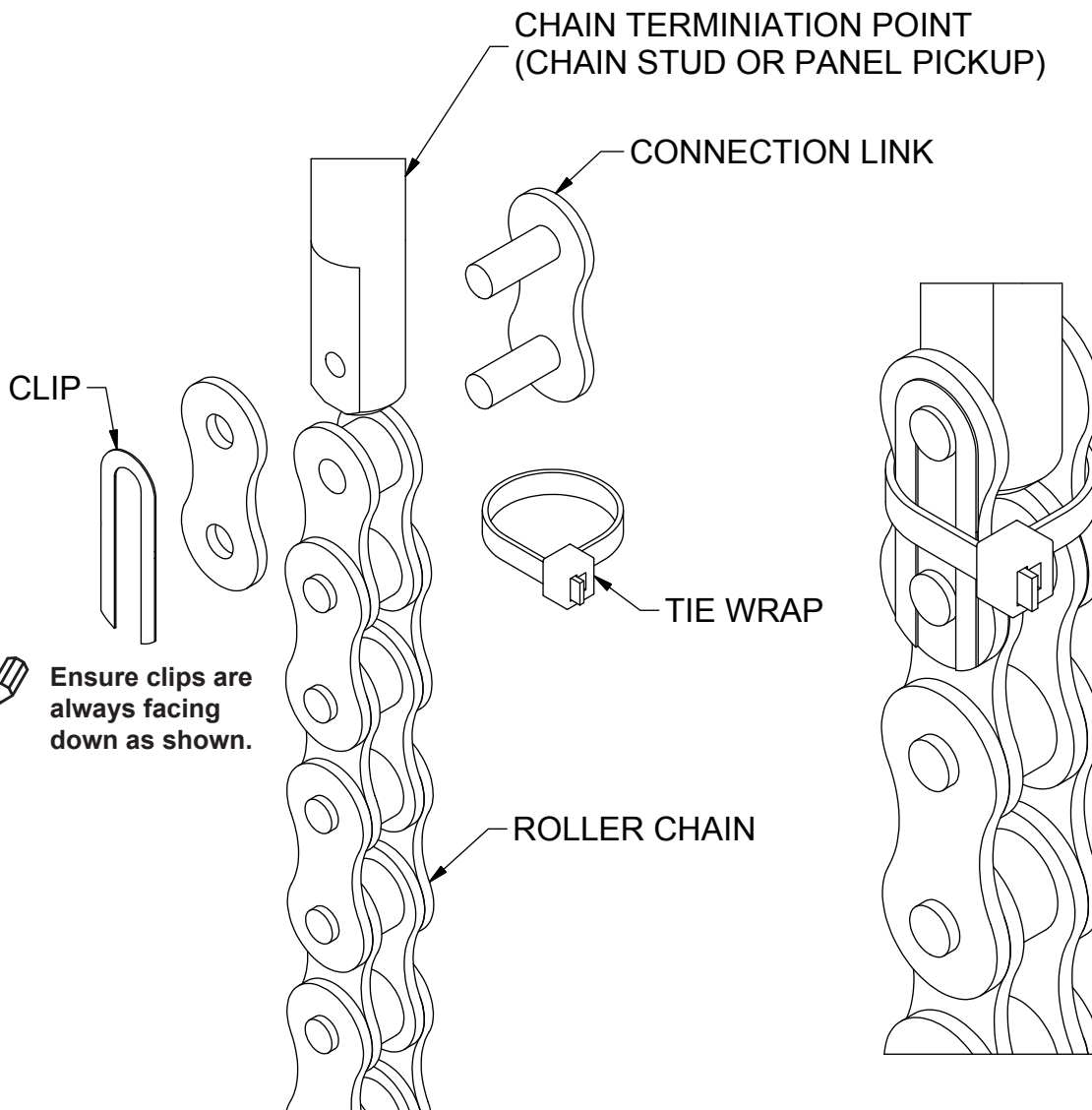
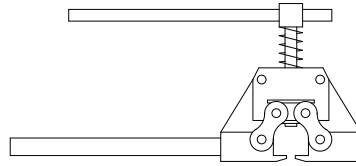

THE PEELLE COMPANY

FREIGHT DOORS | CAR GATES | CAR ENCLOSURES
TECHNICAL SUPPORT 1-800-787-5020 ext 275

23

Guide No. 246-EN

2 SECTION SLIDE-UP CAR DOOR
INSTALLATION GUIDE

Date: May 15 / 2018

21. PANEL ROPING (CHAIN INSTALLATION)

Your installation will either have a single counterweight or a double counterweight as shown below.

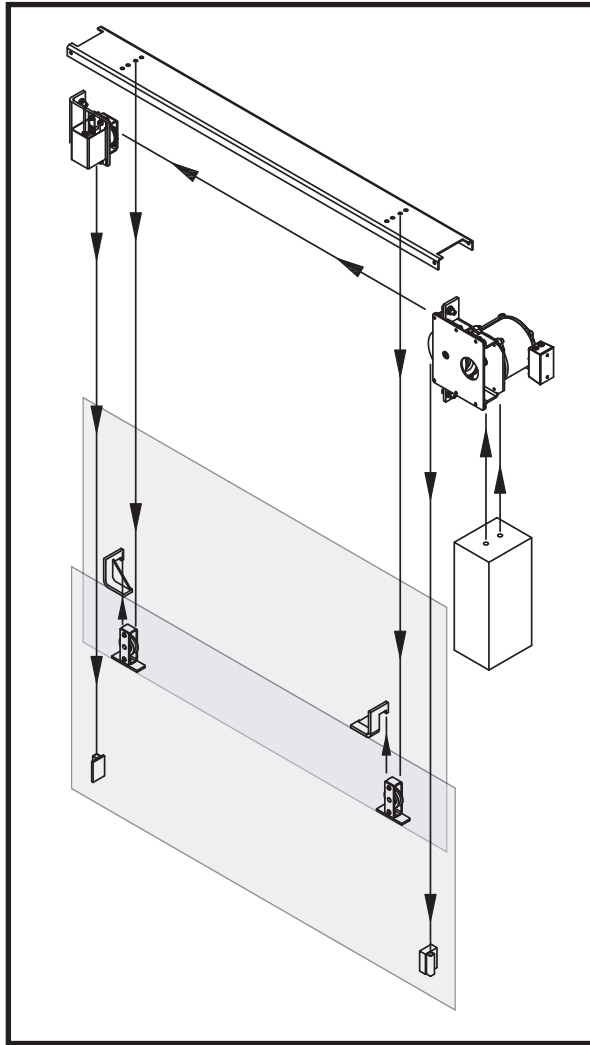

**SINGLE
COUNTERWEIGHT**

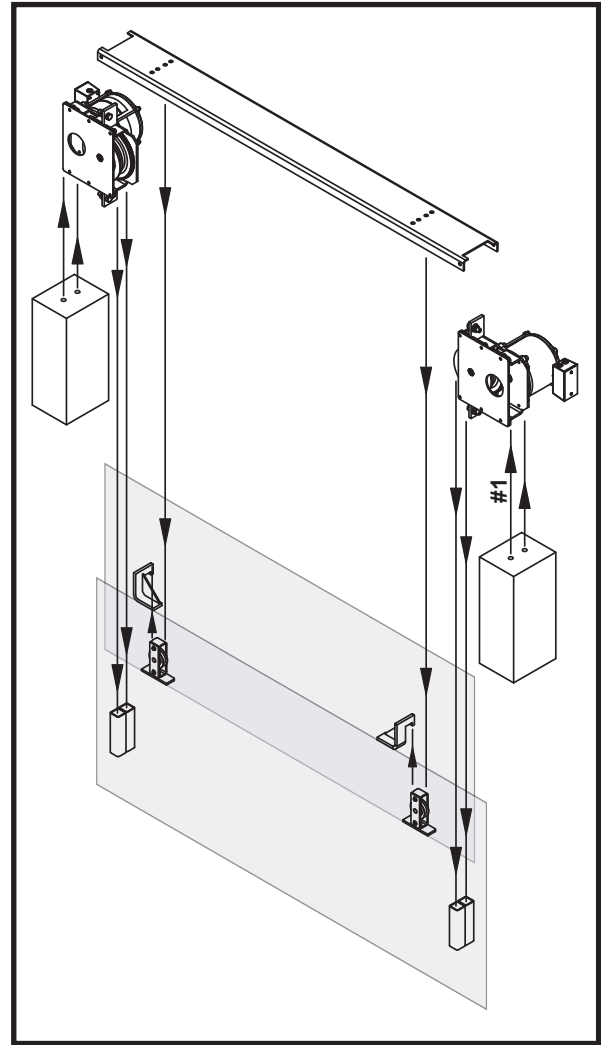

**DOUBLE
COUNTERWEIGHT**



THE PELLE COMPANY

FREIGHT DOORS | CAR GATES | CAR ENCLOSURES

TECHNICAL SUPPORT 1-800-787-5020 ext 275

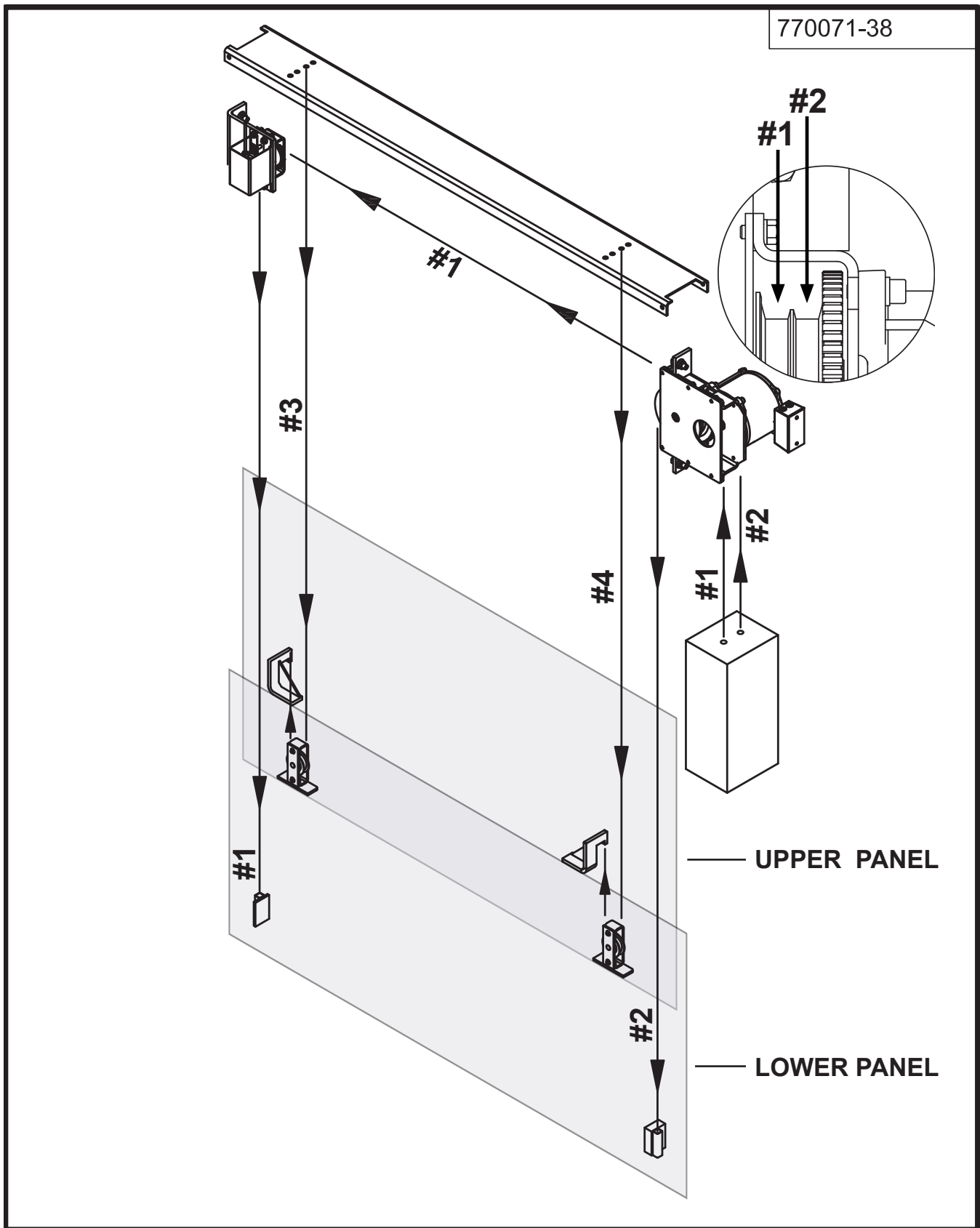

THE PEELLE COMPANY

FREIGHT DOORS | CAR GATES | CAR ENCLOSURES
TECHNICAL SUPPORT 1-800-787-5020 ext 275

Guide No. 246-EN

2 SECTION SLIDE-UP CAR DOOR
INSTALLATION GUIDE

Date: May 15 / 2018

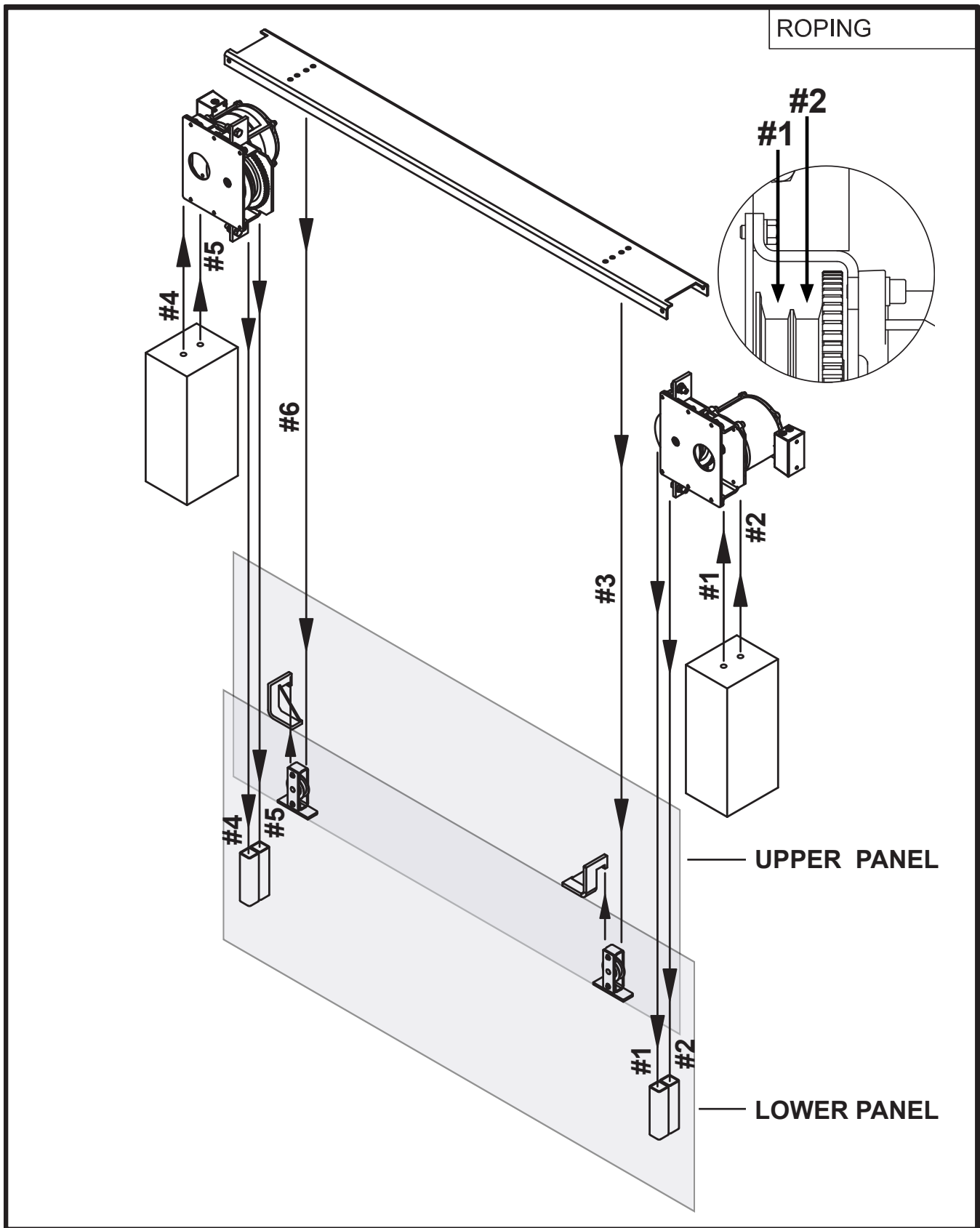

THE PEELLE COMPANY

FREIGHT DOORS | CAR GATES | CAR ENCLOSURES
TECHNICAL SUPPORT 1-800-787-5020 ext 275

Guide No. 246-EN

2 SECTION SLIDE-UP CAR DOOR
INSTALLATION GUIDE

Date: May 15 / 2018

STEP 2

770071-27

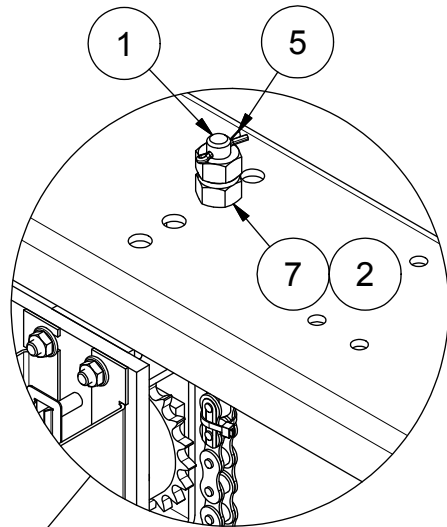

TYPICAL EACH SIDE

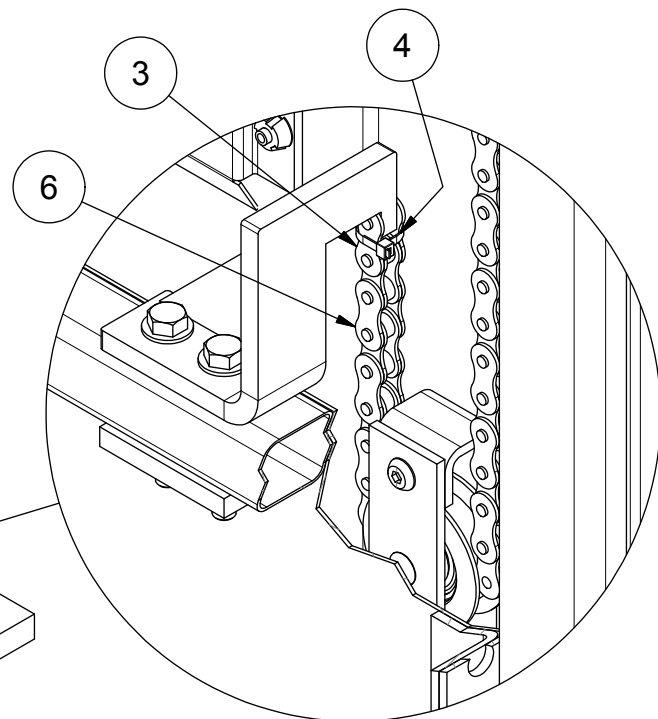
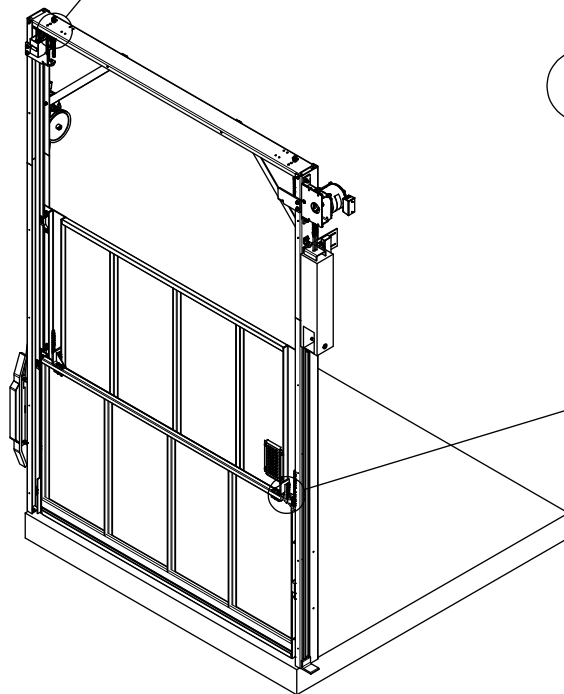

TYPICAL EACH SIDE

7	4	1136510	1/2-13 HEAVY HEX NUT Z
6	2	0179	ROLLER CHAIN
5	2	74210	1/8" x 1" Lg COTTER PIN
4	2	6312	TIE WRAP
3	4	01792	CONNECTING LINK
2	2	1133626	1/2 LOCK WASHER Z
1	2	01475	CHAIN STUD 7" (0179 CHAIN)
ITEM	QTY	PART NO	DESCRIPTION



THE PELLE COMPANY

FREIGHT DOORS | CAR GATES | CAR ENCLOSURES

TECHNICAL SUPPORT 1-800-787-5020 ext 275

27

Guide No. 246-EN

2 SECTION SLIDE-UP CAR DOOR
INSTALLATION GUIDE

Date: May 15 / 2018

STEP 3

770071-26

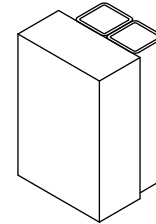
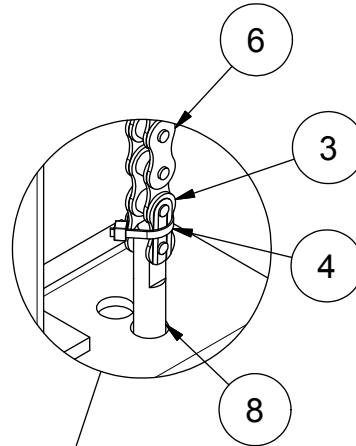
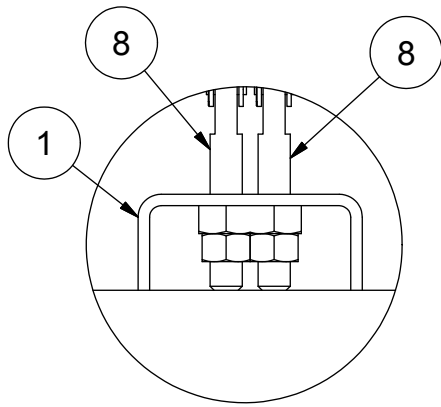

DOUBLE CHAIN HANGER USED FOR DOUBLE COUNTERWEIGHTS

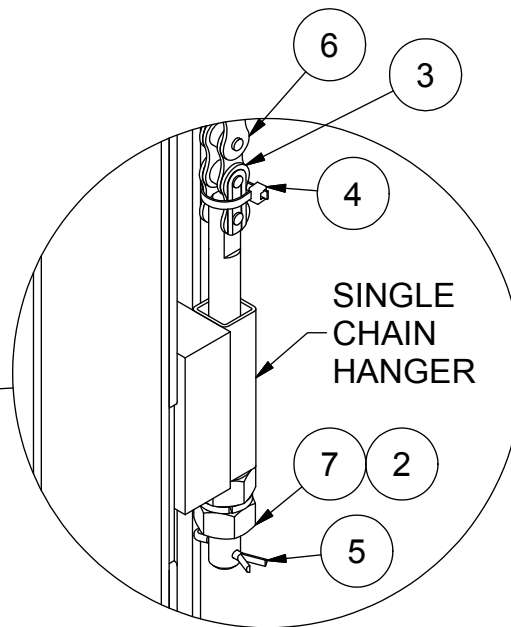
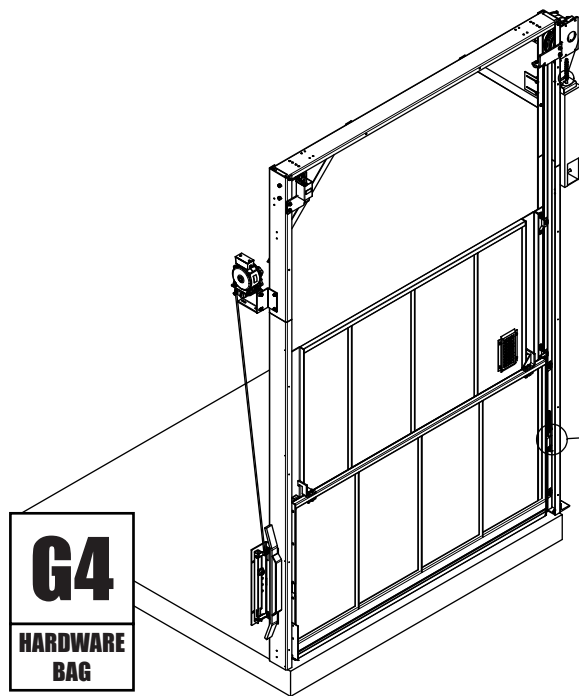

SINGLE CHAIN HANGER

ITEM	QTY	PART NO	DESCRIPTION
8	2	01478	GATE CHAIN ROD - SHORT
7	4	1136510	1/2-13 Low Carbon Zinc Plated Heavy Hex Nut
6	2	0179	ROLLER CHAIN
5	2	74210	1/8" x 1" Lg COTTER PIN
4	4	63123	TIE WRAP
3	4	01792	CONNECTING LINK
2	2	1133626	1/2 LOCK WASHER Z
1	1	770082	COUNTERWEIGHT



THE PELLE COMPANY

FREIGHT DOORS | CAR GATES | CAR ENCLOSURES
TECHNICAL SUPPORT 1-800-787-5020 ext 275

Guide No. 246-EN

2 SECTION SLIDE-UP CAR DOOR
 INSTALLATION GUIDE

Date: May 15 / 2018

24. REMOVE COUNTERWEIGHT STOP ANGLE

770071-21

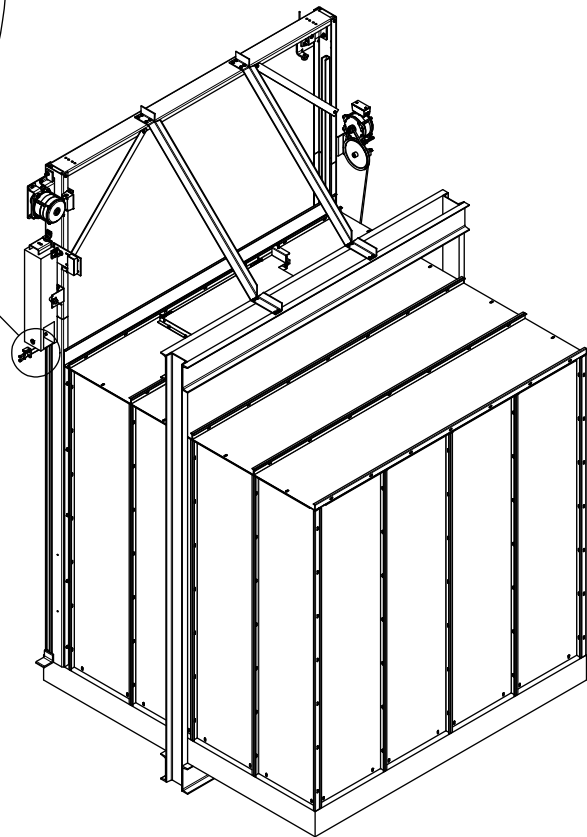
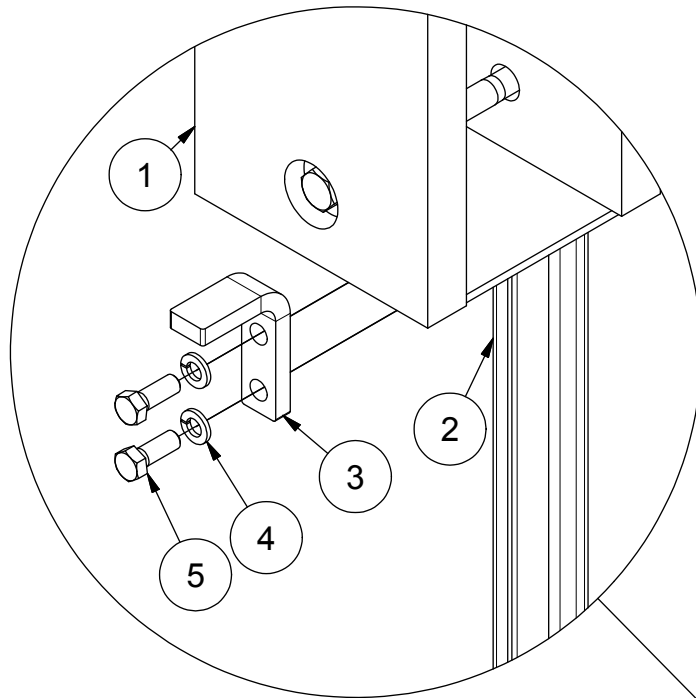

 Remove all CWT Stop Angle and keep for future maintenance.

5	2	800061	3/8"-16 x 1" HH BOLT
4	2	800005	WASHER, LOCK, 3/8"
3	1	066935	COUNTERWEIGHT ANGLE STOP
2	1	770065	GATE RAIL RH CWT ASSEMBLY
1	1	770082	GATE COUNTERWEIGHT ASSY
ITEM	QTY	PART NO	DESCRIPTION



THE PEELLE COMPANY

FREIGHT DOORS | CAR GATES | CAR ENCLOSURES

TECHNICAL SUPPORT 1-800-787-5020 ext 275

29

Guide No. 246-EN

2 SECTION SLIDE-UP CAR DOOR
INSTALLATION GUIDE

Date: May 15 / 2018

25. PULL STRAP INSTALLATION (MANUAL OPERATION)

770071-39

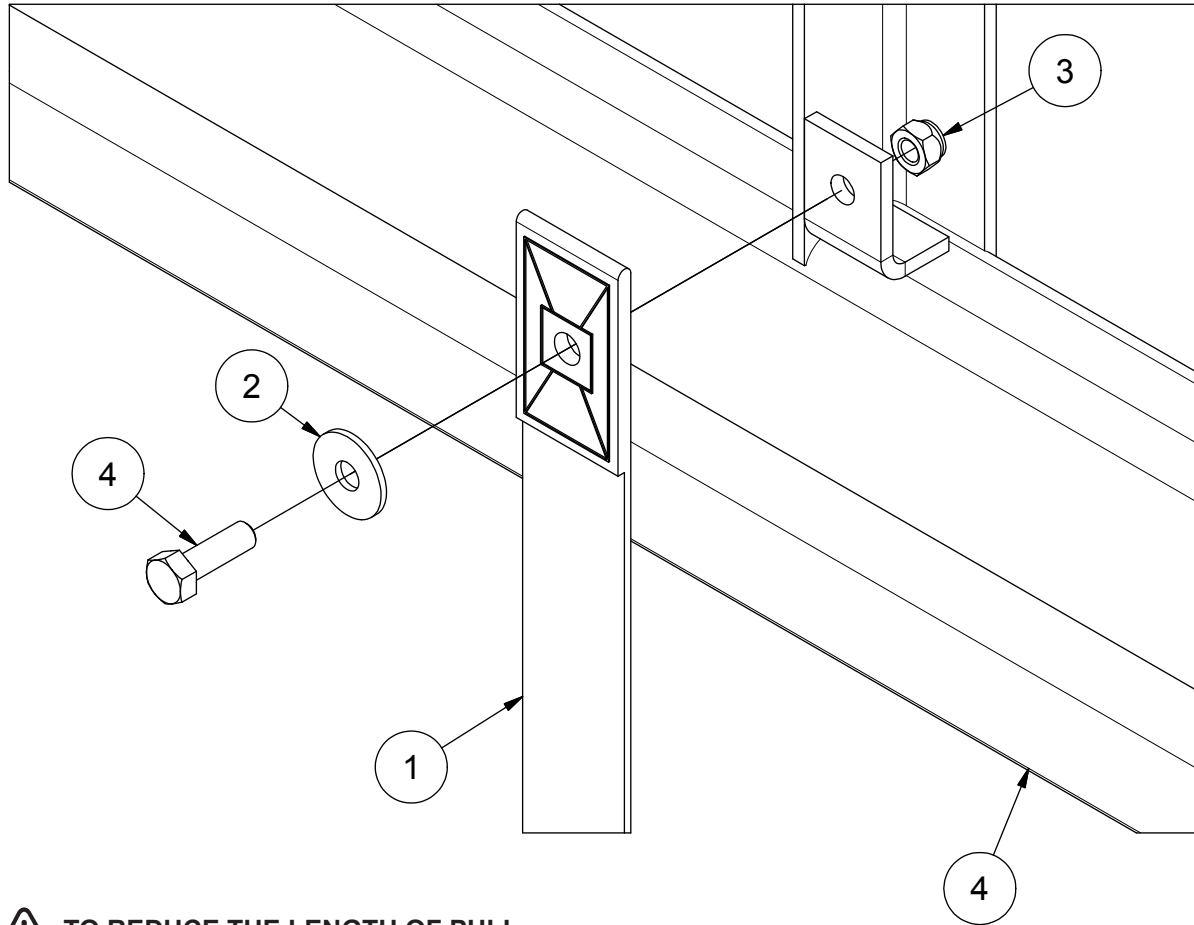

 TO REDUCE THE LENGTH OF PULL STRAP CUT AND SEAR THE END

 DO NOT TIE KNOTS IN STRAPS OR CREATE LOOPS

260018

HARDWARE BAG

4	1	0144484	5/16"-18 UNC x 1" Lg HEX HEAD BOLT ZP
3	1	1137021	5/16"-18 NYLOCK HEX NUT ZP
2	1	1133213	5/16" x 1" FENDER WASHER ZP
1	1	034315	PULL STRAP - 36 IN. LONG
4	1	770046	LOWER PANEL
ITEM	QTY	PART NO	DESCRIPTION



THE PEELLE COMPANY

FREIGHT DOORS | CAR GATES | CAR ENCLOSURES

TECHNICAL SUPPORT 1-800-787-5020 ext 275

30

Guide No. 246-EN

2 SECTION SLIDE-UP CAR DOOR
INSTALLATION GUIDE

Date: May 15 / 2018

26. CAR DOOR / CAR DOOR CONTACT

770071-37



If handing of contact needs to be changed refer to sheet #230000, included with your car door contact package.

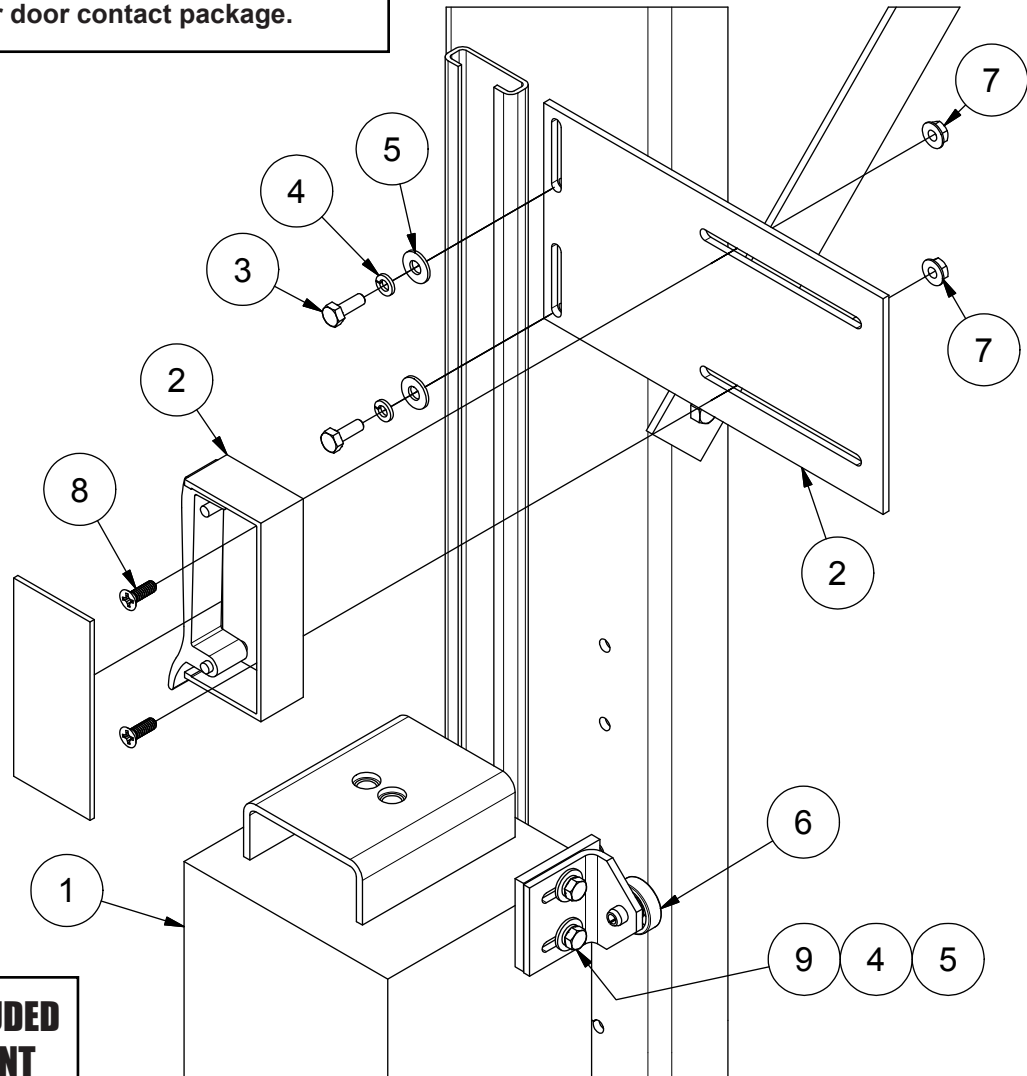

HARDWARE INCLUDED WITH COMPONENT

9	2	110120300	1/4"-20 x 1/2" Lg HEX HD BOLT ZP
8	2	800065	1/4-20 x 3/4" LG FLAT HD SCREW Z
7	2	1137337	1/4-20 SERRATED HEX FLANGE NUT Z
6	1	234201	CONTACT OPERATOR CAM
5	2	1133004	1/4" FLAT WASHER Z
4	2	1133618	1/4 MEDIUM SPLIT LOCK WASHER Z
3	2	110120302	1/4"-20 x 3/4" Lg HEX HD BOLT Z
2	1	2342	CAR DOOR CONTACT
2	1	234200	CONTACT MOUNTING PLATE
1	1	770082	COUNTERWEIGHT
ITEM	QTY	PART NO	DESCRIPTION



THE PELLE COMPANY

FREIGHT DOORS | CAR GATES | CAR ENCLOSURES

TECHNICAL SUPPORT 1-800-787-5020 ext 275

31

Guide No. 246-EN

2 SECTION SLIDE-UP CAR DOOR
INSTALLATION GUIDE

Date: May 15 / 2018

27. ENCODER - DOUBLE COUNTERWEIGHTS

770071-42

This separate encoder option is required if the installation has a counterweight on each side of the car door.

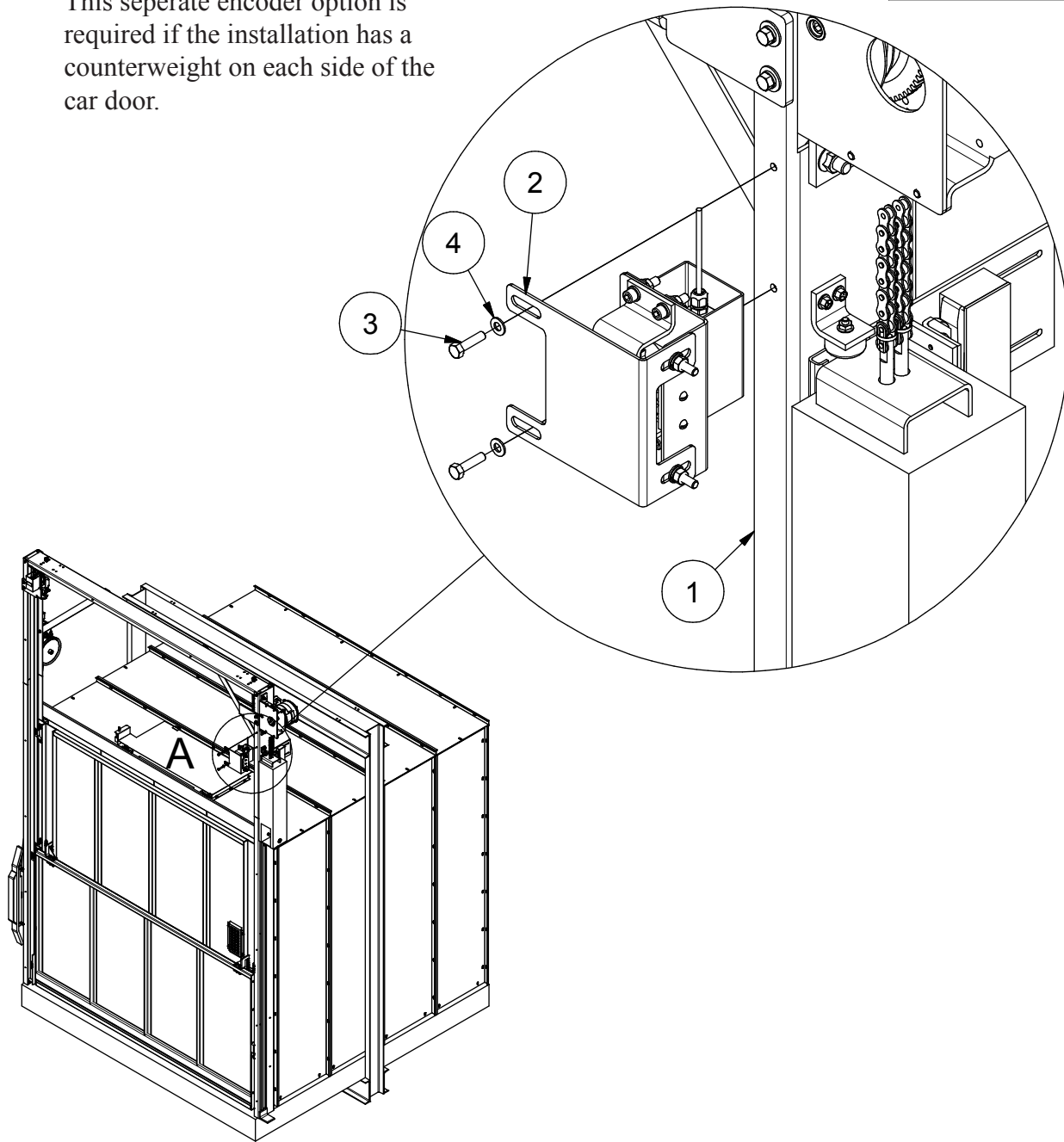

4	4	1133620	5/16" WASHER
3	2	110120326	5/16"-18 UNC x 1-1/4" Lg HEX HEAD BOLT ZP
2	1	770080	SPECIAL ENCODER ASSY
1	1	770065	RAIL, COUNTERWEIGHT - RIGHT HAND
ITEM	QTY	PART NO	DESCRIPTION



THE PELLE COMPANY

FREIGHT DOORS | CAR GATES | CAR ENCLOSURES
TECHNICAL SUPPORT 1-800-787-5020 ext 275

32

Guide No. 246-EN

2 SECTION SLIDE-UP CAR DOOR
 INSTALLATION GUIDE

Date: May 15 / 2018

28. RETIRING CAM TOP ASSEMBLY

770071-18

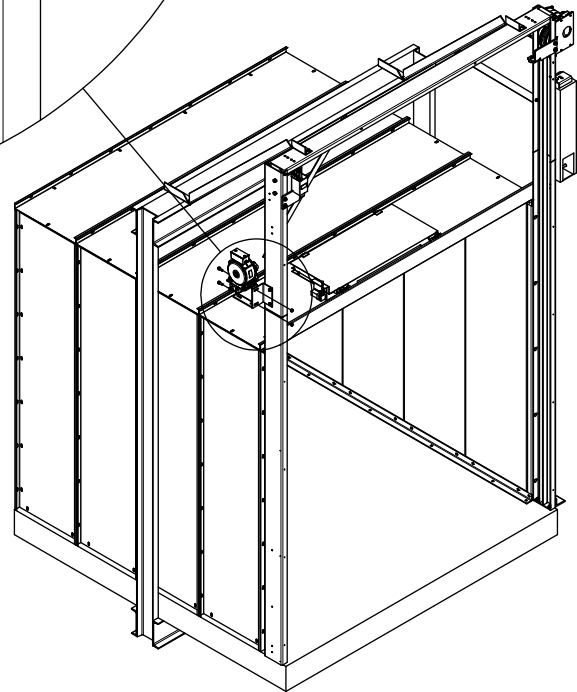
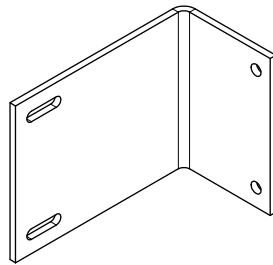
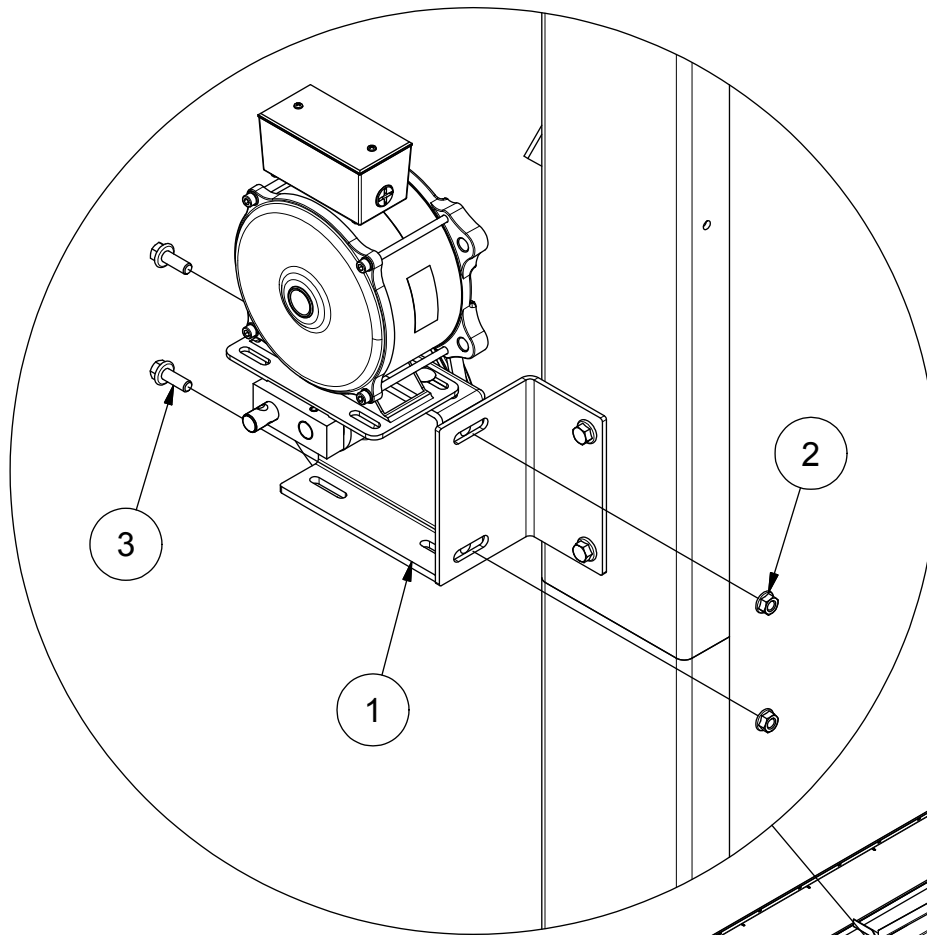

G8
HARDWARE
BAG



Larger bracket provided
if retiring cam and gate
counterweight are located
on the same side.

ITEM	QTY	PART NO	DESCRIPTION
3	2	11104711	3/8"-16 x 1" LG SERRATED FLANGE HEX HED BOLT ZP
2	2	97244	3/8-16 SERRATED FLANGE NUT Z
1	1	233065R	RETIRING CAM TOP ASSY



THE PEELLE COMPANY

FREIGHT DOORS | CAR GATES | CAR ENCLOSURES
TECHNICAL SUPPORT 1-800-787-5020 ext 275

33

Guide No. 246-EN

2 SECTION SLIDE-UP CAR DOOR
INSTALLATION GUIDE

Date: May 15 / 2018

29. RETIRING CAM BOTTOM ASSEMBLY

770071-19

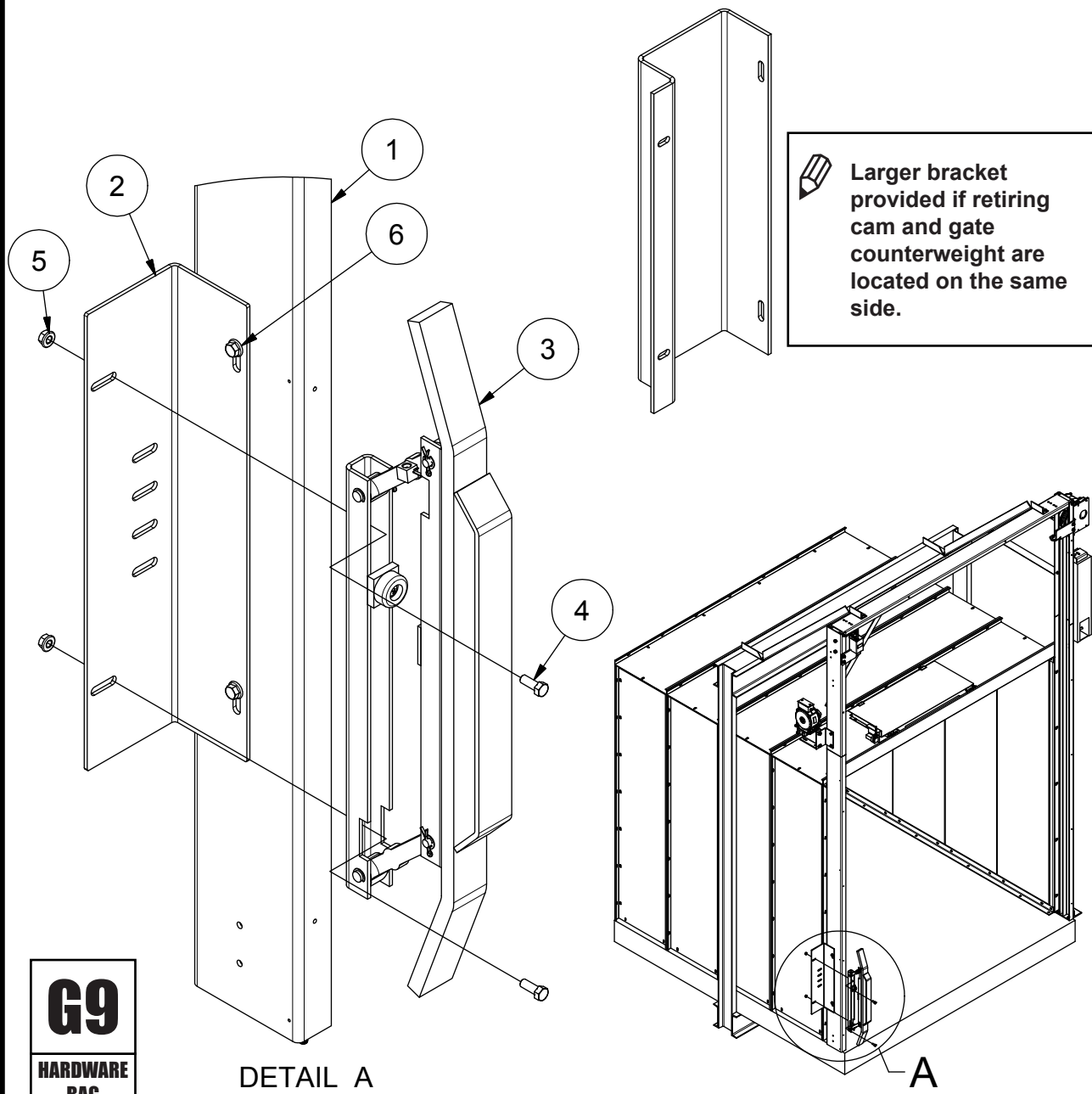

DETAIL A

A

ITEM	QTY	PART NO	DESCRIPTION
6	4	11104709	3/8"-16 x 3/4" LG SERRATED FLANGE HEX HED BOLT
5	2	97244	3/8-16 SERRATED FLANGE NUT Z
4	4	800061	3/8-16 x 1 HH BOLT ZP
3	2	233087	RETIRING CAM BOTTOM ASSEMBLY
2	1	770089	BRACKET, RETIRING CAM BTM ASSY
1	1	770068	RAIL, IDLER - LEFT HAND

30. RETIRING CAM ROD INSTALLATION

770028-25

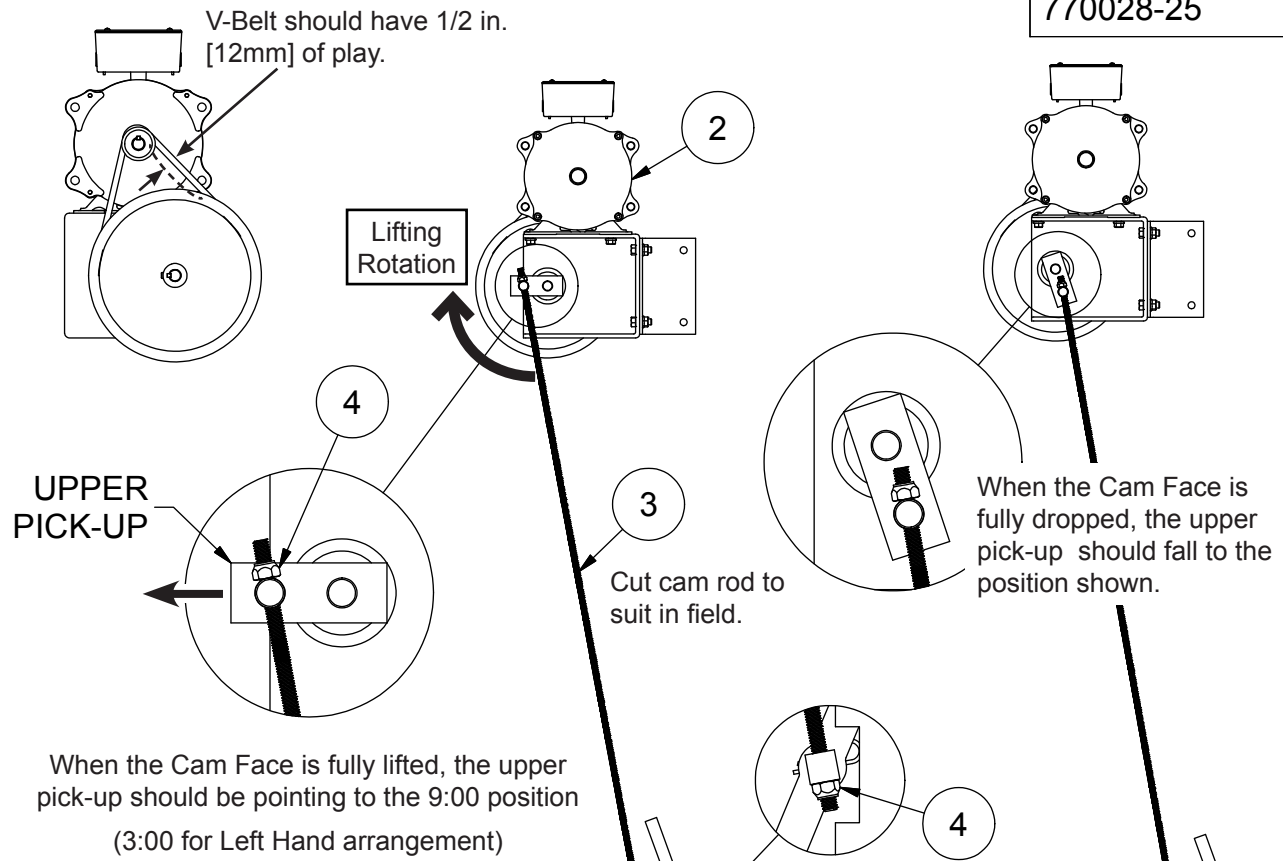

When the Cam Face is fully lifted, the upper pick-up should be pointing to the 9:00 position (3:00 for Left Hand arrangement)



- RIGHT HAND RETIRING CAM ASSEMBLY SHOWN
- LEFT HAND SIMILAR BUT OPPOSITE.
- INSTALL ROD EXACTLY AS SHOWN
- DO NOT USE WASHERS
- DO NOT SANDWICH PICKUP WITH NUTS

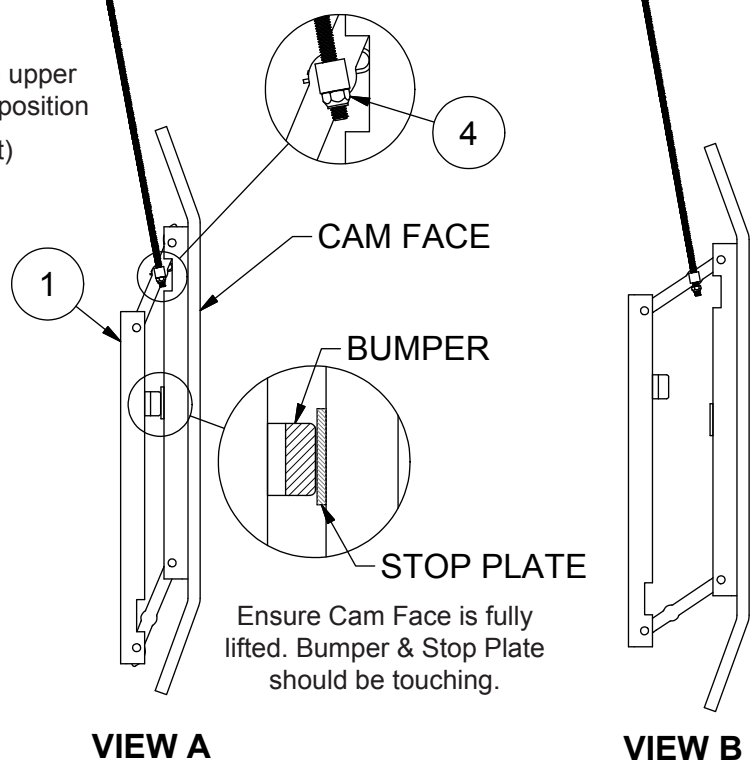

ITEM	QTY	PART NO	DESCRIPTION
4	2	1137021	5/16"-18 NYLOCK HEX NUT ZP
3	1	97179	RETIRING CAM ROD
2	1	233065R	RETIRING CAM TOP ASSY
1	1	233010	RETIRING CAM BOTTOM ASSY



THE PEELLE COMPANY
 FREIGHT DOORS | CAR GATES | CAR ENCLOSURES
 TECHNICAL SUPPORT 1-800-787-5020 ext 275

31. FILLER ANGLES

770071-43

 Set filler angles 6mm [1/4 in] away from face of panels.

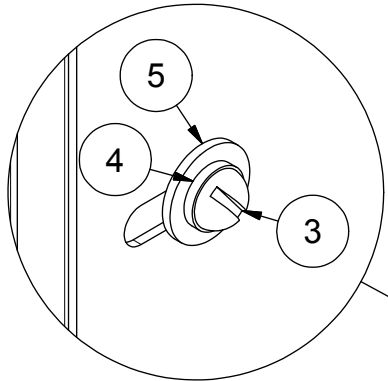

Drill and tap for 1/4-20 screws

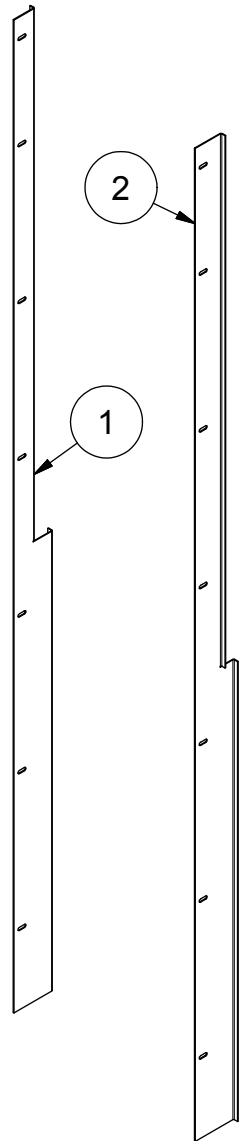
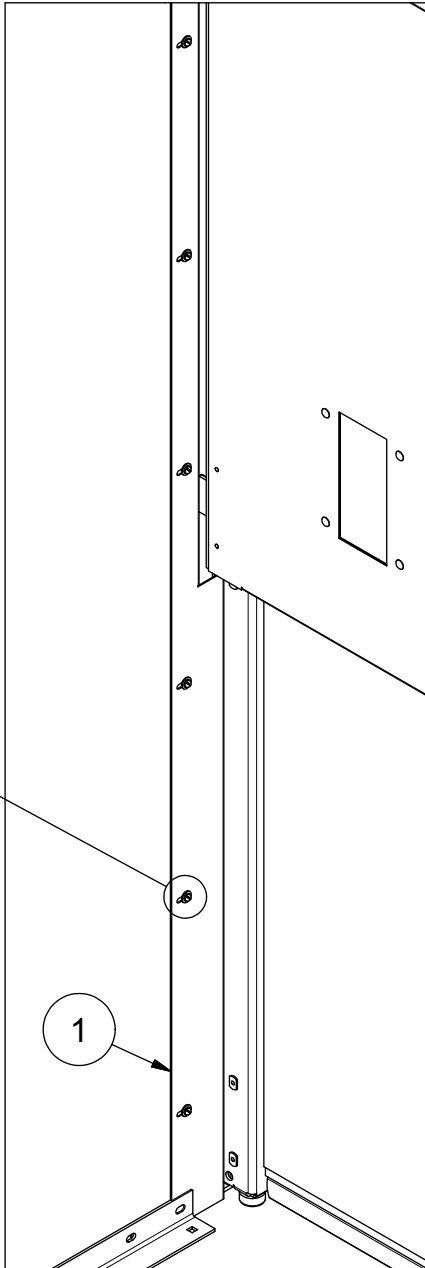

060144
HARDWARE BAG

5	1133004	1/4" FLAT WASHER Z
4	1133618	1/4 MEDIUM SPLIT LOCK WASHER Z
3	21983	1/4"-20 x 1" PH RH SCREW ZP
2	770430R	FILLER ANGLE RIGHT SIDE
1	770430L	FILLER ANGLE LEFT SIDE
ITEM	PART NO	DESCRIPTION



THE PEELLE COMPANY
FREIGHT DOORS | CAR GATES | CAR ENCLOSURES
TECHNICAL SUPPORT 1-800-787-5020 ext 275

32. GOF MICRO SWITCH INSTALLATION

770071-30

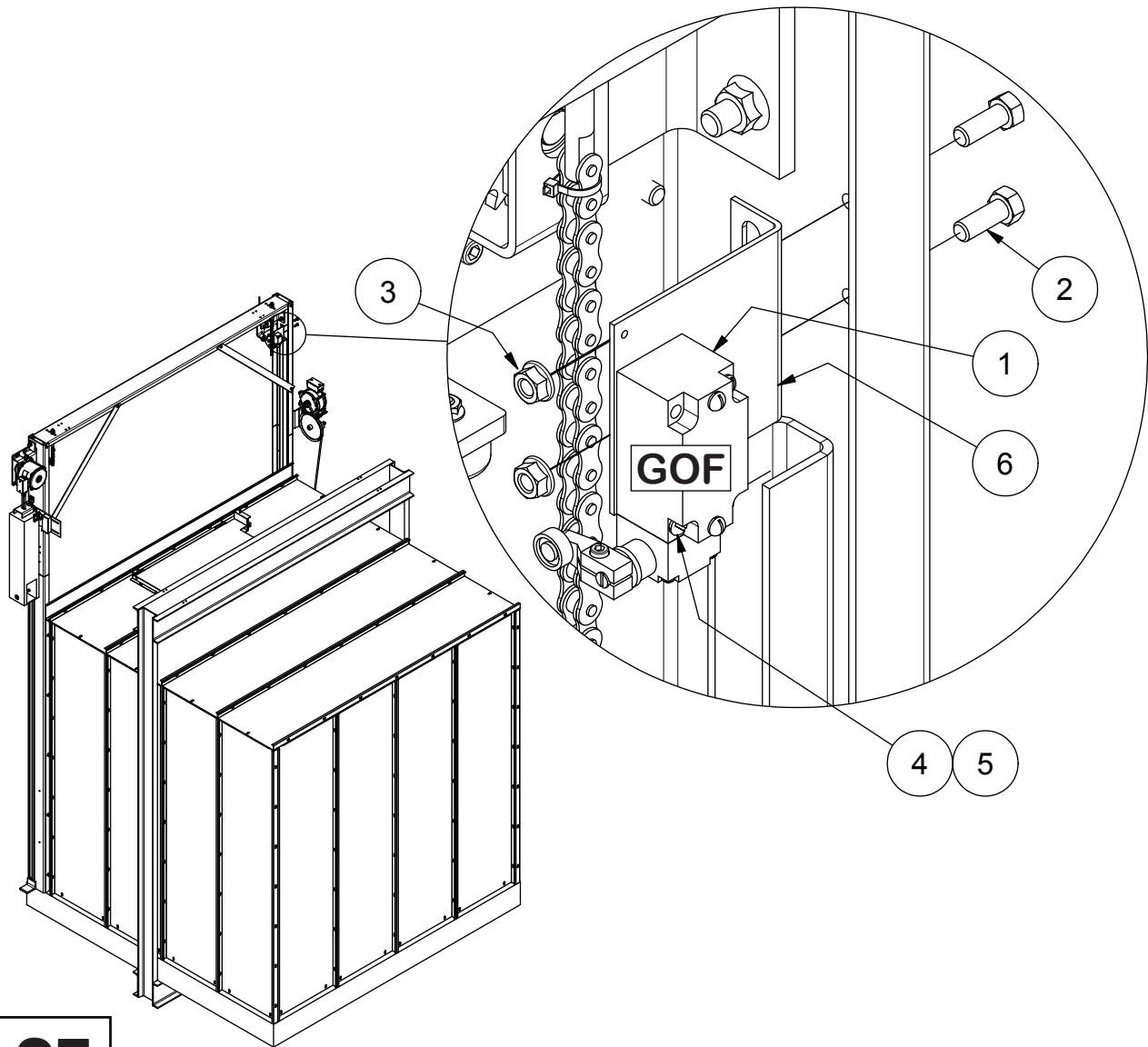

G5
HARDWARE
BAG

ITEM	QTY	PART NO	DESCRIPTION
5	2	1133614	#10 SPLIT LOCK WASHER Z
6	1	770389	PROXIMITY / LIMIT SWITCH MOUNTING BRACKET
4	2	28990	#10-24 x 1 1/2" Lg ROUND HD SCREW ZP
1	1	09686	MICRO SWITCH
3	2	97244	3/8-16 SERRATED FLANGE NUT Z
2	2	800061	3/8-16 x 1 HH BOLT ZP



THE PEELLE COMPANY

FREIGHT DOORS | CAR GATES | CAR ENCLOSURES
TECHNICAL SUPPORT 1-800-787-5020 ext 275

37

Guide No. 246-EN

2 SECTION SLIDE-UP CAR DOOR
INSTALLATION GUIDE

Date: May 15 / 2018

33. CAR DOOR PROXIMITY SENSOR (OPTIONAL)

770071-32

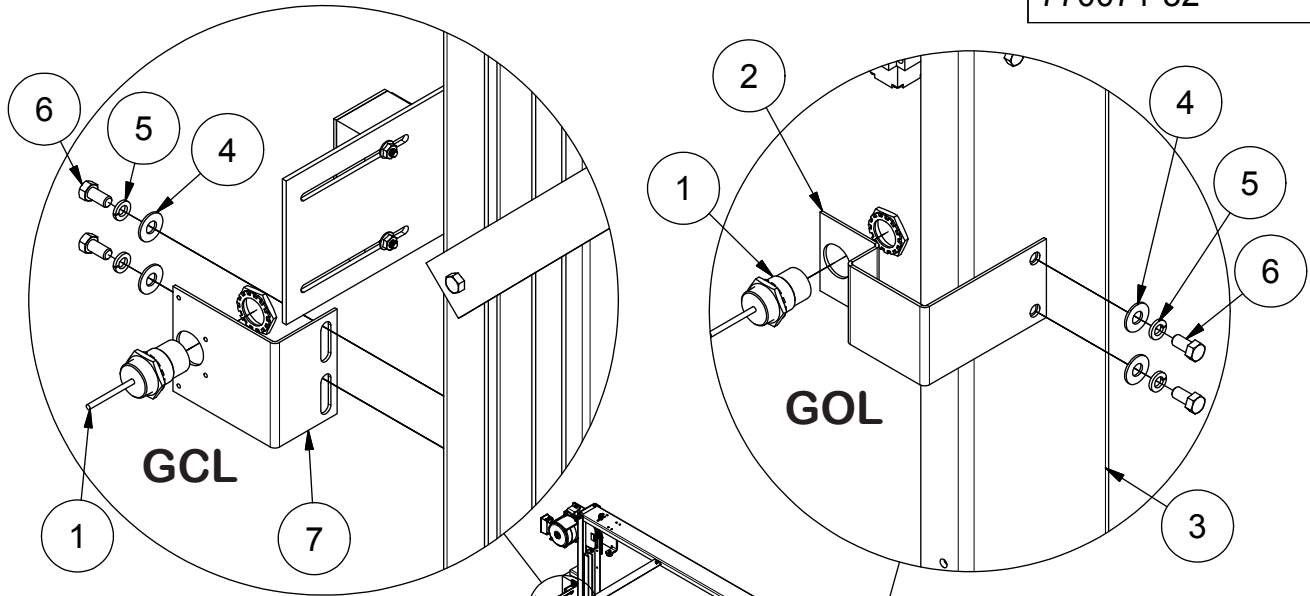

G6
HARDWARE
BAG

7	1	096811	PROXIMITY / LIMIT SWITCH MOUNTING BRACKET
6	2	800073	3/8"-16 x 3/4" LG HEX HD BOLT ZP
5	2	1133622	3/8" LOCK WASHER Z
4	2	1133008	3/8" FLAT WASHER Z
3	1	770068	RAIL, IDLER - LEFT HAND
2	1	770388	PROXIMITY / LIMIT SWITCH MOUNTING BRACKET
1	1	09682	PROXIMITY SENSOR BARREL TYPE
ITEM	QTY	PART NO	DESCRIPTION



THE PEELLE COMPANY

FREIGHT DOORS | CAR GATES | CAR ENCLOSURES

TECHNICAL SUPPORT 1-800-787-5020 ext 275

38

Guide No. 246-EN

2 SECTION SLIDE-UP CAR DOOR
INSTALLATION GUIDE

Date: May 15 / 2018

34. DOOR PROXIMITY SENSOR (OPTIONAL)

770071-31

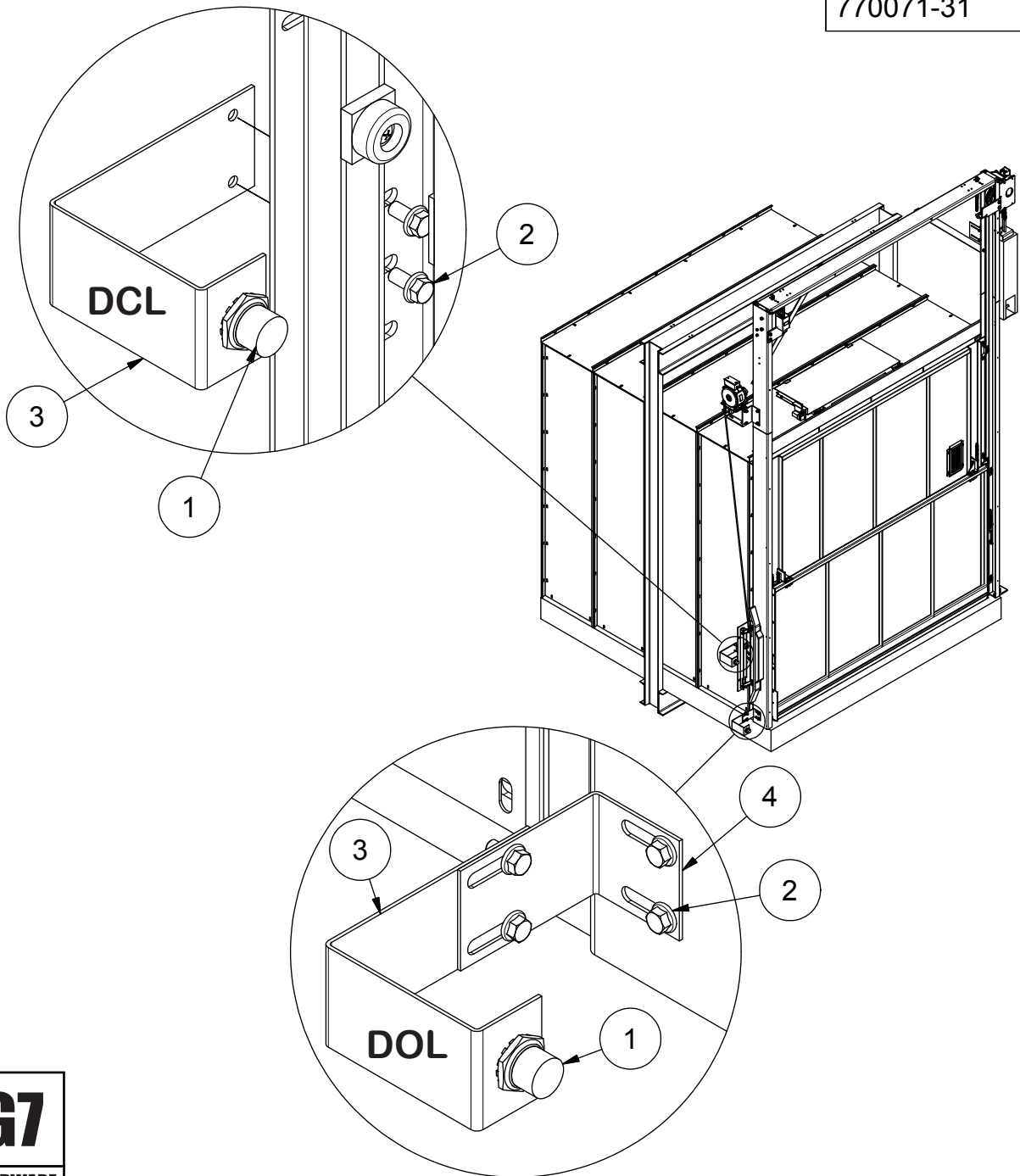

G7
HARDWARE
BAG

4	1	096809	MOUNTING BRACKET, DOL
3	2	096807	BRACKET, DOL & DCL MOUNTING
2	6	11104709	3/8"-16 x 3/4" LG SERRATED FLANGE HEX HED BOLT
1	2	09682	PROXIMITY SENSOR BARREL TYPE
ITEM	QTY	PART NO	DESCRIPTION



THE PEELLE COMPANY

FREIGHT DOORS | CAR GATES | CAR ENCLOSURES
TECHNICAL SUPPORT 1-800-787-5020 ext 275

39

Guide No. 246-EN

2 SECTION SLIDE-UP CAR DOOR
INSTALLATION GUIDE

Date: May 15 / 2018

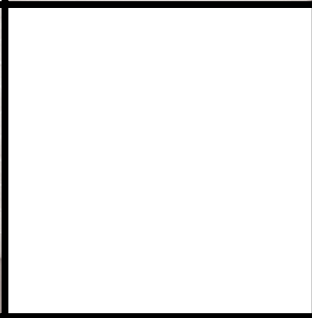

THE PEELLE COMPANY

FREIGHT DOORS | CAR GATES | CAR ENCLOSURES
TECHNICAL SUPPORT 1-800-787-5020 ext 275

Guide No. 246-EN

2 SECTION SLIDE-UP CAR DOOR
INSTALLATION GUIDE

Date: May 15 / 2018