

267-EN

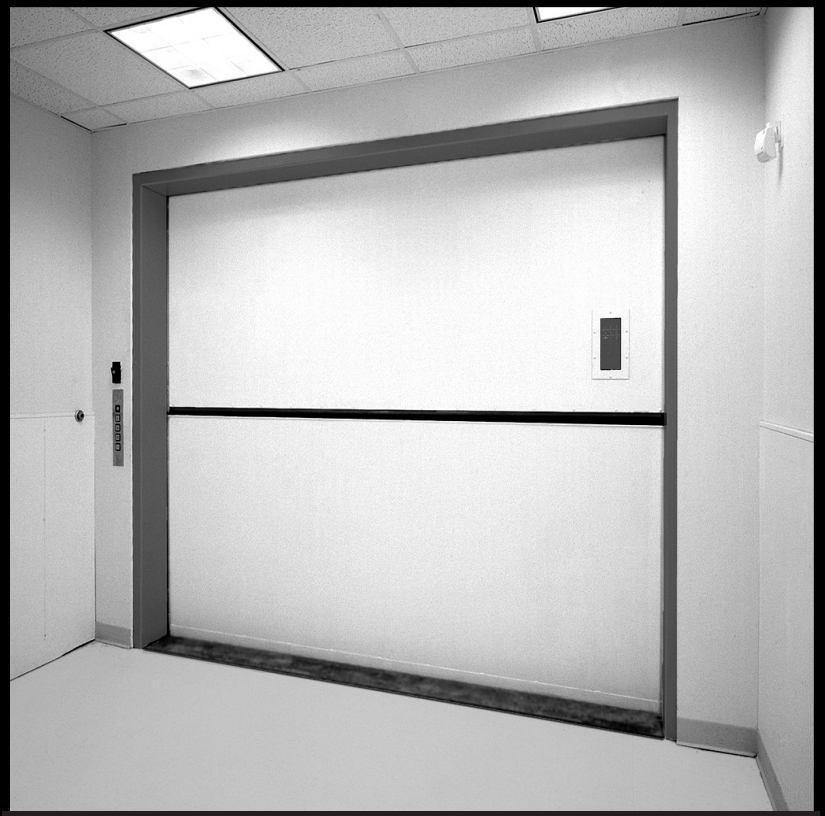

ATTENDANT OPERATED ENTRANCE MANUAL BIPARTING DOOR INSTALLATION GUIDE

**Regular
Pass & Extended**



THE PEELLE COMPANY

FREIGHT DOORS | CAR GATES | CAR ENCLOSURES

TECHNICAL SUPPORT 1-800-787-5020 ext 275

Guide No. 267-EN
ATTENDANT OPERATED
ENTRANCE

Date: Oct 26/2020

Contents

1. FORWARD.....	1
2. ELEVATOR CONTRACTOR RESPONSIBILITIES.....	1
3. BEFORE STARTING INSTALLATION.....	1
4. JOB NUMBER IDENTIFICATION.....	2
5. HANDING.....	2
6. BIPARTING LANDING DOOR INSTALLATION.....	3
6.1. GENERAL.....	3
6.2. DOOR GUIDE RAILS TYPES.....	3
6.3. DOOR GUIDE RAILS - LOCATION.....	4
6.4. DOOR GUIDE RAILS – INSTALLATION.....	5
6.5. DOOR SHEAVES INTERLOCKS & OTHER COMPONENTS.....	6
6.6. DOOR PANELS.....	6
6.7. LOWER PANELS.....	6
6.8. UPPER PANELS.....	7
6.9. DOOR CHAINS, CHAIN RODS & TENSION LATCHES.....	7
6.10. TO ADJUST DOOR CHAINS AND DOOR PANELS IN THIS ORDER:.....	8
6.11. ADJUST PANEL BETWEEN GUIDES.....	9
6.12. DOOR SIDE TENSION LATCHES.....	9
6.13. FOR INTERLOCKS COMPONENTS AND SILLS, OPERATORS AND OTHER COMPONENTS, REFER TO SECTIONS <i>23.6 TO 23.9</i>	9
7. FLOOR HEIGHT CHECK.....	10
8. CAR CLEARANCE CHECK.....	11
9. AVERAGE OPENING CENTERLINE.....	12
9.1. MARK JAMB POSITION AT EACH FLOOR.....	12
9.2. AVERAGE OPENING CENTERLINE.....	12
10. LOCATING CENTER OF THE OPENINGS.....	13
10.1. POSITION THE CENTER OF THE GAUGE ROD ONTO THE AVERAGE OPENING CENTER LINE.....	13
10.2. NEXT TRANSFER THE DBG TO THE PLATFORM.....	13
11. BUILDING SILL LEVEL CHECK.....	14
11.1. LEVEL THE SILL.....	14
11.2. IDENTIFY LOWEST SIDE.....	14
11.3. POSITION THE RAIL.....	14
12. DOOR GUIDE RAIL INSTALLATION - OVERVIEW.....	15
13. RAIL INSTALLATION POSITIONING.....	16
14. RAIL BOLTING.....	17
14.1. LOWEST RAIL BOLTING.....	17
14.2. SHIM RAIL AS NECESSARY.....	17



THE PEELLE COMPANY

FREIGHT DOORS | CAR GATES | CAR ENCLOSURES

TECHNICAL SUPPORT 1-800-787-5020 ext 275

Guide No. 267-EN
ATTENDANT OPERATED
ENTRANCE

Date: Oct 26/2020

14.3.	IN ORDER TO KEEP RAILS PLUMB AND MAINTAIN THE CORRECT CAR CLEARANCE USE "0629 RAIL SHIMS".....	17
15.	HOW TO USE GAUGE ROD.....	18
16.	RAIL INSTALLATION - OPPOSITE SIDE.....	19
17.	INTERMEDIATE OR TOP RAIL OVERVIEW.....	20
18.	ATTACH CLIPS ANGLES TO WALL.....	21
19.	COMPONENT INSTALLATION.....	22
19.1.	MANUAL SHEAVES.....	22
19.2.	PLUG ROD INSTALLATION.....	23
19.3.	RO INTERLOCK INSTALLATION.....	24
19.4.	SPLICE PLATE & PARKING DEVICE (MECHANICAL LOCK).....	25
19.5.	BAR KEEPER.....	26
20.	PANEL INSTALLATION.....	27
20.1.	INSTALL A HOIST OR CHAIN FALL.....	27
20.2.	POSITION PANEL CRATE AND CONNECT STRAPS.....	28
20.3.	LIFT PANEL AND REMOVE CRATE.....	29
20.4.	ROTATE THE PANEL.....	30
20.5.	HOIST THE PANEL INTO POSITION.....	31
20.6.	INSTALL THE LOWER DOOR PANEL.....	32
20.7.	INSTALL THE UPPER DOOR PANEL.....	33
21.	HANGING THE PANELS.....	34
21.1.	CHAIN OVERVIEW - REGULAR BI-PARTING.....	34
21.2.	INSTALL THE TENSION LATCH.....	35
21.3.	INSTALL THE CHAIN ROD.....	36
22.	PULL STRAPS (MANUAL OPERATION).....	37
22.1.	RATCHET PIECE AND ROLLER KEEPER.....	38
23.	FINAL ADJUSTMENTS.....	39
23.1.	MANUAL SHEAVE ADJUSTMENT.....	40
23.2.	LEVEL THE PANELS.....	41
23.3.	LOWER PANEL ADJUSTMENT.....	42
23.4.	SIDE TO SIDE PLAY.....	43
23.5.	TENSION LATCH ADJUSTMENT.....	44
23.6.	ADJUST THE TAMPER RESISTANT PLUGGING DEVICE.....	45
23.7.	RO INTERLOCK & BAR KEEPER SET AND PIN.....	46
23.8.	INSTALL KEEPER HOOK, AND SET POSITION OF PARKING DEVICE (MECHANICAL LOCK).....	47
23.9.	SET THE ROLLER ARM.....	48



THE PEELLE COMPANY

FREIGHT DOORS | CAR GATES | CAR ENCLOSURES

TECHNICAL SUPPORT 1-800-787-5020 ext 275

Guide No. 267-EN

**ATTENDANT OPERATED
ENTRANCE**

Date: Oct 26/2020



THE PEELLE COMPANY

FREIGHT DOORS | CAR GATES | CAR ENCLOSURES

TECHNICAL SUPPORT 1-800-787-5020 ext 275

Guide No. 267-EN
ATTENDANT OPERATED
ENTRANCE

Date: Oct 26/2020

1. FORWARD

The following Installation Guide is for a standard Peelle product assembly. However, Peelle products are designed-built to suit many elevator conditions such as very large openings, limited elevator shaft dimensions, hoistway conditions and unique lift designs. Therefore special designs, arrangements or add-ons may not be covered in this manual. Refer to the installation drawings provided with your order for instructions on special components or arrangements.

If you have any questions, concerns or require further details regarding your installation please call 1 (905) 846-4545 x 275, please have your Peelle Job Number handy. A Peelle technical support expert will help you save time and keep the installation moving.

2. ELEVATOR CONTRACTOR RESPONSIBILITIES

PRIOR TO THE START OF PEELLE INSTALLATION, THE FOLLOWING SHALL BE PROVIDED BY OTHERS

- 1) A running and operational elevator with platform, car safeties and a temporary run box. There should be no hot wires running to the equipment that Peelle will be replacing. This includes hall push buttons even if not being replaced by others.
- 2) Clearances in conformance with Peelle layout drawings.
- 3) Unless furnished by Peelle, all necessary electrical piping and wiring material required for the Peelle equipment. Electrical piping and wiring materials shall be on the job site and readily available to Peelle personnel.
- 4) Electrical power in the machine room adequate for Peelle equipment and Peelle control system.
- 5) 115V (230V where applicable), single phase power adequate for power tools.
- 6) A suitable, secure, and conveniently located storage area for Peelle furnished materials, tools, and other equipment necessary to the installation of Peelle equipment. This area should be as close to the elevator as possible.
- 7) Completed hoistway walls with entrance frames installed in conformance with Peelle requirements. Refer to Peelle Entrance Frame Installation Guide 208.

3. BEFORE STARTING INSTALLATION

- A) This is a two person job
- B) Safety Equipment
 - Personal Protective Equipment
 - Workplace Barricades
 - Fall Protection
- 3) Hoist or Crane
 - Mounted at top of hoistway
 - Centered in the doorways



THE PEELLE COMPANY

FREIGHT DOORS | CAR GATES | CAR ENCLOSURES

TECHNICAL SUPPORT 1-800-787-5020 ext 275

1

Guide No. 267-EN
ATTENDANT OPERATED
ENTRANCE

Date: Oct 26/2020

4) Tools required

- Measuring Tape
- Level
- Set Square
- Carpenters Clamps 24" [610mm]
- Hammer
- High Speed Drill
- Drill Bits HSS 11/32" [9mm] (5 per landing)
- Hammer Drill
- Masonry Bits 5/16" [8mm]
- Masonry Bits 1/2" [14mm]
- Impact Wrench
- 9/16" [14mm] socket
- Angle Grinder
- Chain Pin Extractor (Chain Breaker) (Pelle Part No. 0608)
- Open and closed ended wrenches (3/8" to 7/8") [10mm to 22mm]
- Socket set (3/8" to 7/8") [10mm to 22mm]
- Screwdriver Set
- Pliers

4. JOB NUMBER IDENTIFICATION

- Locate the pelle job number on the rails and door panels.
- Job numbers should match and include the line designation.
- Example:

100000 1A	100000 = Job Number 1 = Floor Designation A = Front Line (C = Rear Line)
------------------	--

5. HANDING

- The following is an illustration of a typical freight elevator hoistway. The left and right hands (LH and RH) of door/gate hardware are viewed from inside the car looking out.
- Instructions shown here are typical for a car gate with a Pelle right hand mounted interlock and retiring cam. For left hand installations opposite configuration will be used.
- Line "A" Front and Line "C" Rear/Opposite are used by Pelle. Where there is more than one line of doors, the front is usually the side with the most doors.

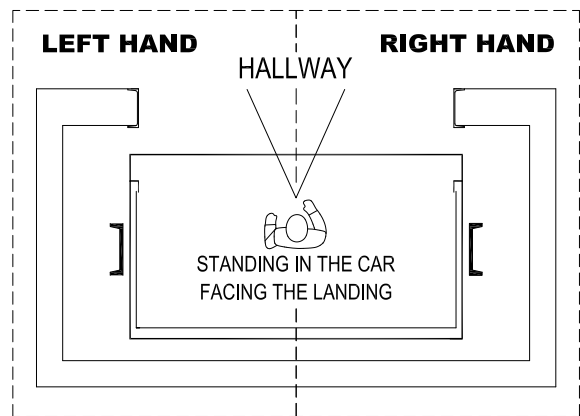

PLAN VIEW OF HOISTWAY



THE PELLE COMPANY

FREIGHT DOORS | CAR GATES | CAR ENCLOSURES
TECHNICAL SUPPORT 1-800-787-5020 ext 275

6. BIPARTING LANDING DOOR INSTALLATION

6.1. GENERAL

Install hoistway landing doors before the car gate(s). If possible, install doors before the freight car enclosure (cab) is installed.

Use the moving elevator car platform for door installation. A full kit of hand tools will be required, including open-end wrenches, socket wrenches, screwdrivers, and various types of pliers. In addition, a good supply of drills (especially 9mm [11/32 in]) will be needed since these become dull rapidly from contact with concrete which is unavoidable when drilling into the channel steel entrance frame for door rail installation.

A heavy duty drill will be required. An electric impact wrench should be used for installing the self-tapping rail bolts.

Hoisting equipment will be required. Chain fall or electric hoist rated 1/2-ton [500 kg] are needed for door panels. Make sure hoists and slings are in good condition.

6.2. DOOR GUIDE RAILS TYPES

The doors are guided in parallel door tracks on each side of the opening.

Single track rails are for regular type doors. Double track rails are for pass type doors (*see pg 3, Figure 1*).

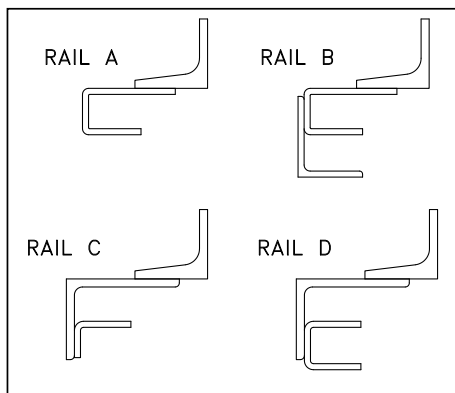

Figure 1 - Door Rail Types

Rail description may be broken down further into three categories: upper guide rails, intermediate guide rails and lower guide rails (*see pg 3, Figure 2*)

Intermediate rails are one-piece rails, from slightly below the centerline of the door opening on one floor to slightly below the centerline of the opening at the

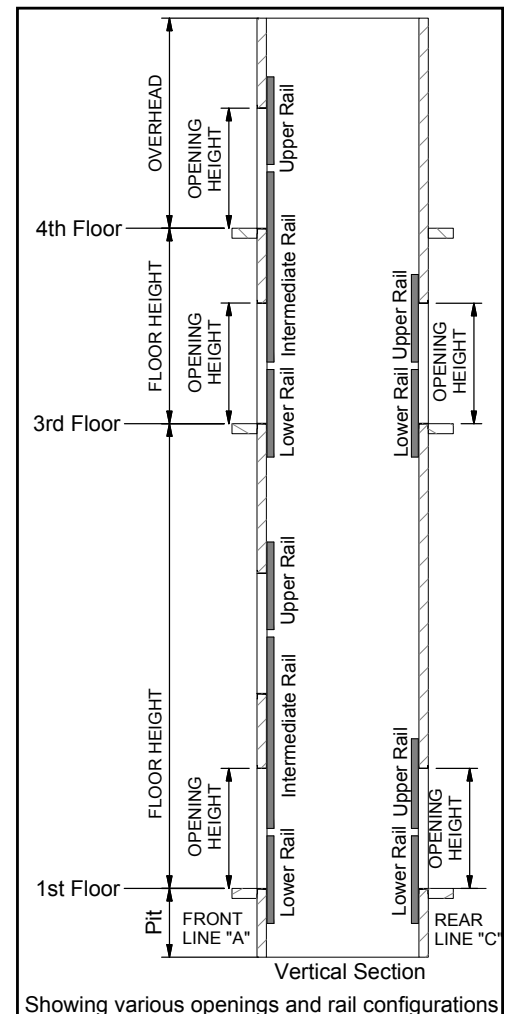

Figure 2 - Door Rail Categories



THE PEELLE COMPANY

FREIGHT DOORS | CAR GATES | CAR ENCLOSURES

TECHNICAL SUPPORT 1-800-787-5020 ext 275

floor above or below. Intermediate rails are used on most installations. Upper rails and lower rails are always used.

Door guide shoes never travel across a split in the rails except for very long rails that need to be split for shipment purpose.

Guide Rails are identified with the Peelle Job Number and floor designation (*see pg 2, sec 4*).

6.3. DOOR GUIDE RAILS - LOCATION

The first step in the installation of freight elevator doors is the determination of the best horizontal location for rails on the flange of the vertical jambs. Take a survey of the actual jamb positions compared to the Peelle L-1 layout drawing.

This can be done by in one of the following ways:

- a) Using the moving platform as a plumb mark if the car is operating, (*see pg 12, sec 9*).
- b) Drop a plumb line or laser plumb guide.

For (a), a mark is made on the movable platform to simulate a plumb line. Take a measurement from that line as you would from a plumb line. For (b), a plumb line (wire) may be dropped near one side of the door frames. It is to extend from above the top door head jamb to within a few inches of the pit floor. A self-leveling laser plumb bob is worth the investment. Sit the device on the floor of the pit.

Check the vertical alignment of the vertical jambs. Take measurements at each floor to both jambs from the car platform mark or from the plumb wire. Fill out the chart provided (*see pg 11, sec 8*). Using these measurements and a comparison to the Peelle L-1 layout drawing, get an average guide rail setting for all floors in that line. Rails are to be set one above the other (in vertical alignment) from the bottom to the top of the hoistway. Hold the required distance between guides (DBG) of the doors. A Door Gauge Rod, made from steel angle, is provided.

It may be necessary to shift the entire line of door guide rails to one side or the other in order to compensate for frames that are out of alignment while maintaining the required DBG. Misaligned frames may be fixed by welding steel bar (10mm by 65mm [3/8 in. by 2 1/2 in] by the height of opening) to the vertical jamb utilizing some of the clear opening space.

Remember to hold the required car-to-sill clearance (car platform to frame sill clearance) so the door will fit in that space. If frames are not parallel with the elevator platform use the rail shims to keep the rail straight and plumb. If more than 6mm [1/4"] of rail shims is required, weld a steel flat / bar (min. 6mm x 65mm [1/4" x 2 1/2"]) to the full length of the jamb flange, in order to make up the space.

Doors require that the distance between guides (DBG) dimension be 3mm [1/8 in] longer than the dimension between the base of the throats of the guide shoes. This should be checked on two or more door panels. Care in using the door gauge rod is important because at the same time the rails must be set exactly plumb. If you are careful with this procedure, you will install



THE PEELLE COMPANY

FREIGHT DOORS | CAR GATES | CAR ENCLOSURES

TECHNICAL SUPPORT 1-800-787-5020 ext 275

4

Guide No. 267-EN

**ATTENDANT OPERATED
ENTRANCE**

Date: Oct 26/2020

free running doors as the overall side-to-side play movement (left-right) will be 3mm [1/8 in] as recommended.

6.4. DOOR GUIDE RAILS – INSTALLATION

Install the door rails, beginning with the rails in the lowest landing extending into the pit.



THE ENDS OF THE RAILS ARE NOT SET TO VERTICAL CENTERLINE OF OPENING. RATHER, SET THE SILL MARKS ON THE RAILS LEVEL WITH DOOR FRAME SILLS.

If the floor heights are in accordance with the door layout drawing, there will be approximately 25mm [1 in] vertical gap between rails slightly below the centerline of the openings. This gap accommodates slight floor height variations (*see pg 10, sec 7*).

Check the frame sill for level across each opening (*see pg 14, sec 11*). The sill mark on the rail is to be placed even with the sill. If the sill is not level, the lowest side establishes the trucking sill position for both sides of the door trucking sill. After the door is installed, the door trucking sill must be level from one side of the door to the other, and at the same height as the building sill low point. This can be further accomplished by adjusting the sill stops. Precise rail position is important.

For each door opening, hold the rail from one side in place. Preferably this is the interlock side rail. Securely clamp it in place with two 610mm [24"] steel carpenter clamps (*see pg 16, sec 13*) Set it plumb. Set it in vertical alignment with rail above/below. Position the sill mark even, vertically, with the building sill. The top of the rail is usually 50mm [2"] down from the vertical center line of the opening above. Drill and bolt the rail using the self-tapping, locking, washer head bolts (*see pg 17, sec 14*).

If the rail is at the proper vertical position, the interlock mounting holes in the rail will then be in the proper position. The interlock has 50mm [2"] of initial installation vertical adjustment.

The opposite rail, at each opening, should be located with the door gauge rod to maintain the proper door DBG (Distance between Guides) and setting its sill mark (*see pg 18, sec 15*). Use the door gauge rod at the top and bottom of the opposite rail. Check the opposite rail with a level or plumb line. Hold the rail with clamps (*see pg 19, sec 16*).

The holes to fasten the rails should be drilled using a 9mm [11/32"] high speed drill bit for the self-tapping bolts. Holes are drilled with the rails clamped in place. Bolts may be driven with an electric impact tool. The self-tapping bolts supplied have a washer head with locking. Additional washers are never used with rail mounting bolts. Rail mounting holes are slotted vertically and the bolts should be located at the top of the vertical slots.

The intermediate rails for the next opening are to be placed in exact vertical and horizontal alignment with the rails already installed, using each sill mark as the vertical positioning point (*see pg 20, sec 17*). The same rail installation process is then repeated up the hoistway with all pairs of guide rails.

In between landing openings, the door rail passes beyond the jamb and there is no steel on which to bolt. In this section fasten the rail to the wall with angle brackets by using masonry



THE PEELLE COMPANY

FREIGHT DOORS | CAR GATES | CAR ENCLOSURES

TECHNICAL SUPPORT 1-800-787-5020 ext 275

anchors (*see pg 21, sec 18*).

In the pit, where the door rail passes below the jamb, secure the rail with angle brackets and masonry anchors. In the case of a water-proof pit where you cannot drill into the sealed pit wall, steel spreaders are to be used. These spreader flats are bolted to angle brackets attached to the rails and tie the two rails together (*see pg 21, sec 18*).

6.5. DOOR SHEAVES INTERLOCKS & OTHER COMPONENTS

A pair of door sheaves (pulleys) is necessary at each opening to support the chain (and thus the doors). The sheaves allow movement for opening and closing. Holes are provided in the door rails above the head-of-frame to bolt the sheaves in place (*see pg 22, sec 19.1*).

The lowest floor door will be provided with a parking device which allows the attendant to close and lock the door with the elevator parked at the lowest landing.

An unlocking key will be provided to unlock the lowest landing door from the room side.

Temporarily mount the mechanical lock using the bottom holes / slots provided (*see pg 24, sec 19.3*) exact vertical position will be set later

6.6. DOOR PANELS

There is an upper and a lower door panel for each opening. Door panels for most openings are too heavy to move into place by hand and will require the use of a drywall dolly to move about. They will have to be set in place with a chain fall or electric hoist. If door panels are bowed from shipment, straighten before installing. Handle with care and protect fascia surface until completion. To check if the door panels have been twisted during shipment, place panel on hoistway side of door rails, check if all four corners touch (not twisted).

Door panels are identified by the same system of factory markings as the rails (*see pg 2, sec 4*).

Before installing a door panel, be sure that no excess concrete mortar protrudes from the hoistway shaft wall that could scrape the door face and slow it down. Break off any suspected pieces with a hammer.

6.7. LOWER PANELS

Unbolt the shoes opposite the interlock side. Peelle door guide shoes are solid, adjustable, fire-rated shoes.

The side of the panel with the largest (extended) shoe bar is the interlock side. The shoes are to be removed from the side opposite the interlock in order to install the lower panel.

Pick up the lower panel. The chain hoist must be securely placed high enough in the hoistway shaft to prevent being hit by the top landing upper panel when opened. Use a sling around each end of the top of the lower panel (*see pg 32*). Hoist the lower panel. Push the lower door panel into its approximate position, allowing the shoes to enter the guide rail. Push the other side (with the shoes removed) into position. Holding the lower panel in its correct location,



slide the removed shoes along the rail into their positions on the lower panel. Bolt shoes onto the door panel. Use the hoist to lower the lower panel to its full open position, resting upon the sill stops.

The lower panel includes the “trucking sill”. It is design-built strong to permit freight to be moved over it on pallet trucks in and out of the elevator. The trucking sill rests on adjustable sill stops when the door is open (*see pg 7, Figure 3*). The sill stops are adjustable to permit the trucking sill to be level from one side to the other when resting on the stops. While the stops should already be level, the stops are adjustable to obtain a level door trucking sill that is at the same vertical position as the door frame sill low point. The trucking sill must be level even if the building sill is not level. There are 8 possible adjustments using the stop casting along with the small angle spacer provided.

6.8. UPPER PANELS

Remove the shoes from either side of the upper panel. Move the upper panel under the chain hoist. Using the chain hoist, start to pick up the upper panel with a sling. Take the slack out of the hoisting chain and sling (*see pg 33*). Push the upper panel into the rails. Reinstall the shoes.

Hoist the upper panel to its full open position. Do not stand underneath the panel being hoisted. Hoist the panel slightly above its full open height to install chains (*see pg 33*).

6.9. DOOR CHAINS, CHAIN RODS & TENSION LATCHES

A pair of chains and chain rods are provided for each opening. Their function is to couple the door panels together so they will be counterbalanced. This coupling will relate the motion of the upper panel with the motion of the lower panel. One end of each chain is connected to a side tension latch, which is attached to the upper door panel. The other end of each chain is connected to a chain rod, which is connected to the lower panel. The chain rods are threaded to allow for chain adjustment, when needed later.

With the upper panel hoisted, install the side tension latches onto the pivots at each side and lock in place with the spring pins (*see pg 35, sec 21.2*).

Install the threaded end of the chain rod into the chain rod holder. Put one nut, a lock washer and second nut onto the threads, then cotter pin; move nuts and lock washer down to cotter pin, hold rod up temporarily with vice grips (*see pg 36, sec 21.3*).

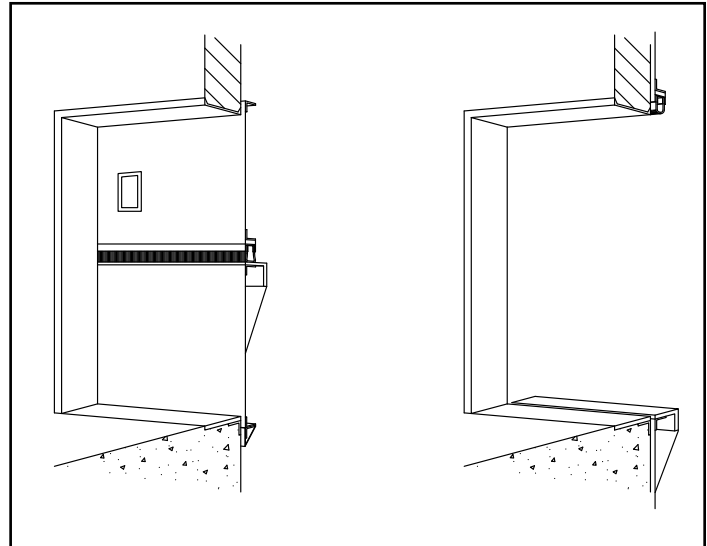

Figure 3 - Door Closed & Opened



THE PEELLE COMPANY

FREIGHT DOORS | CAR GATES | CAR ENCLOSURES
TECHNICAL SUPPORT 1-800-787-5020 ext 275

7

Guide No. 267-EN
ATTENDANT OPERATED
ENTRANCE

Date: Oct 26/2020

Attach one end of the chain to the side tension latch pivot of the upper panel with a chain connector link. Pull the chain up through the sheave cover to thread the chain over the sheave. Mark and cut the chain to length at the top of the chain rod. Grind of the end of the pin and hammer out the pins. Use a chain breaker device if you have one. Attach the free end of the chain to the rod using chain connector link (*see pg 36, sec 21.3*).

Use the hoist to lower the upper panel until it is held up by the chains. Make sure that all chain connecting links are properly connected. Chain connector clip should have legs pointing downward. Wrap connecting links and connector clips at each end of the chain with the nylon tie-wraps provided (*see pg 36, sec 21.3*). Peelle door and gate chains are lubricated by the manufacturer. NO OIL or GREASE is required upon initial installation.

6.10. TO ADJUST DOOR CHAINS AND DOOR PANELS IN THIS ORDER:

After the chains are connected, the door panels must be properly adjusted. Most of the adjustment, if necessary, is accomplished by moving the nuts up on the chain as rod (*see pg 41, sec 23.2*). Some links of chain may have to be removed to achieve desired adjustment.



Door panels, when opening and closing must also have their weight in balance. Do not leave the doors in an open position without a barricade. Bolt the doors closed or lock them with an interlock.

TO POSITION PANELS FOR FULL OPENING

With the lower door panel resting evenly on both stops and the trucking sill level from side to side and at the same height as the door frame sill low point (*see pg 42, sec 23.3*). The upper panel should be fully open (including the astragal cushion strip). Adjust chains. Remove some chain links if necessary. No portion of the astragal should project below the head-of-frame when the doors are fully open. Do not judge chain adjustment solely by the door frame sill or head-of-frame. They might not be level (do not use a level on the astragal of upper panel). Stand on lower panel; the upper panel should be the same distance from the lower panel, measured at both ends of the opening width.

TO ELIMINATE GAP BETWEEN PANELS IN CLOSED POSITION (*SEE PG 41, SEC 23.2*)

With the doors fully closed and with the side tension latch hooks loosened and positioned temporarily out of the way, adjust the nuts on the chain rods to eliminate the panel gap across the opening. Move nuts up on the rod of the side of the door that tends to stay apart. This provides a closed meeting between panels in the closed position. Doors properly sized for an opening must overlap the head-of-frame and the sill by 50mm [2 in].

TO LOWER THE CENTER POINT (DAY LIGHT) OF THE PANELS

Keep the door panels in the same closed position (with no opening at the sill or at the head-of-frame). Move nuts on both rods downward the same distance each side. Make sure the nuts are almost touching the cotter pin near the bottom. This allows for the easy future chain stretch adjustment. If there is slack in the chain, remove chain links to remove slack.



THE PEELLE COMPANY

FREIGHT DOORS | CAR GATES | CAR ENCLOSURES

TECHNICAL SUPPORT 1-800-787-5020 ext 275

8

Guide No. 267-EN
ATTENDANT OPERATED
ENTRANCE

Date: Oct 26/2020

TO REMOVE CHAIN LINKS

Reset the lower panel on the sill stops, use a chain fall to get the upper panel fully open, make sure the nuts are almost touching the cotter pins near bottom of each chain rod, clamp the rods with vice grips positioned on top of the rod holders, disconnect the chains at the latches, remove links from both chains with a chain breaker.

Reconnect the chains. Carefully remove the chain hoist from the upper panel and remove the temporary clamps (vice grips) from the chain rods.

6.11. ADJUST PANEL BETWEEN GUIDES

Allow 3mm [1/8 in] overall side-to-side play. The side-to-side play should be the same at the top and bottom shoes of each panel to make sure the doors operate freely. There should be little need for chain adjustment if the rails are plumb and the panels are an equal distance apart vertically, both sides, when fully open. Only if necessary, adjust the “adjustable” shoes inward or outward to achieve 3mm [1/8 in] side-to-side play. (*see pg 43, sec 23.4*)

6.12. DOOR SIDE TENSION LATCHES

Side tension latches, provided on each side of the doors, minimizes separation of the door panel meeting edges when closed.

Side tension latches are important and must be set with enough tension to keep the doors from separating when closed. The latch must pivot freely. Remove any paint or burr from the pivot area and lubricate with grease or oil. Set the pivot stop bolt. To set the pivot stop bolt, the tension hook must be loosened and tightened temporarily out of the way. Loosen, but do not remove the tension hook mounting bolts. Set the stop bolt. Then reposition the hooks to pressure the door panels closed. The roller keeper should be in the proper horizontal position for the tension latch hook to be plumb when the doors are closed. If not, the upper panel and lower panel rails might not be meeting properly. Adjust if necessary. The roller keeper should also meet the latch hook in the proper vertical location. It should be snug in the lower curve of the latch. (*see pg 44, sec 23.5*)

6.13. FOR INTERLOCKS COMPONENTS AND SILLS, OPERATORS AND OTHER COMPONENTS, REFER TO SECTIONS 23.6 TO 23.9



THE PEELLE COMPANY

FREIGHT DOORS | CAR GATES | CAR ENCLOSURES

TECHNICAL SUPPORT 1-800-787-5020 ext 275

9

Guide No. 267-EN

**ATTENDANT OPERATED
ENTRANCE**

Date: Oct 26/2020

8. CAR CLEARANCE CHECK

770440-01

Measure the distance between the platform & entrance frame (both side) see dimension A and B. Measure at floor level and top of opening. Dimensions will be used later for adjusting and shimming the rails.

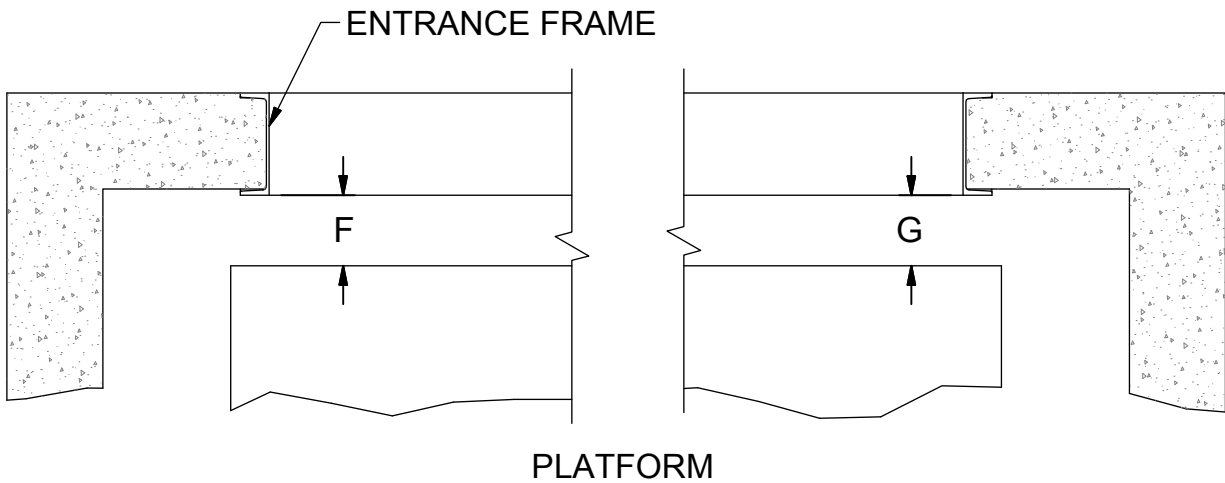

	TOP		
	BOTTOM		
	TOP		
	BOTTOM		
	TOP		
	BOTTOM		
	TOP		
	BOTTOM		
FLOOR	POSITION	F	G
FRONT LINE "A"			

	TOP		
	BOTTOM		
	TOP		
	BOTTOM		
	TOP		
	BOTTOM		
FLOOR	POSITION	F	G
REAR LINE "C"			

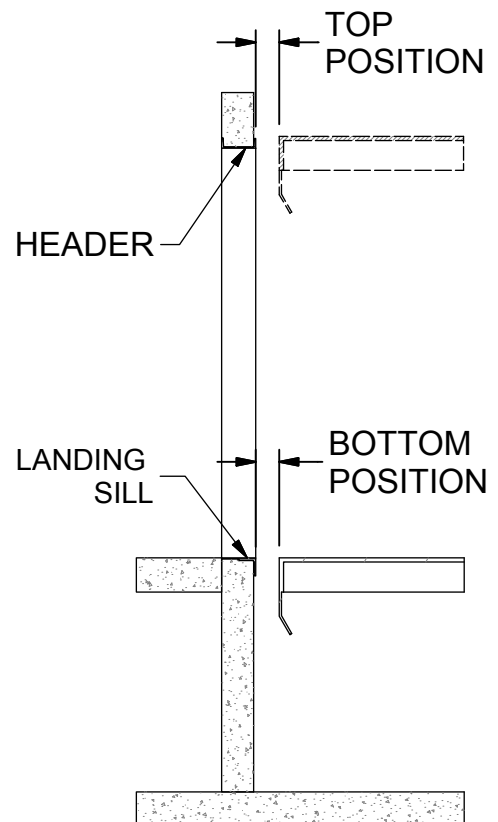

THE PEELLE COMPANY

FREIGHT DOORS | CAR GATES | CAR ENCLOSURES
TECHNICAL SUPPORT 1-800-787-5020 ext 275

11

Guide No. 267-EN
ATTENDANT OPERATED
ENTRANCE

Date: Oct 26/2020

9. AVERAGE OPENING CENTERLINE

770441-01



Openings are generally not perfectly centered. Follow these steps to get entrance aligned at each floor.

9.1. MARK JAMB POSITION AT EACH FLOOR

Mark platform showing the position of the frame at each floor.

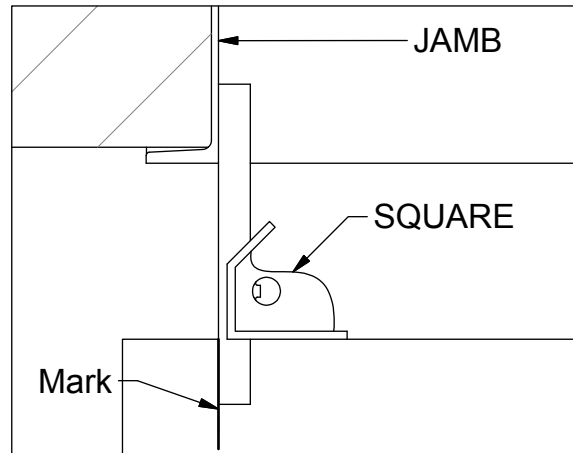

9.2. AVERAGE OPENING CENTERLINE

Determine your “Average Opening Centerline”. Measure the distance between the 2 farthest marks on your platform and mark the center.

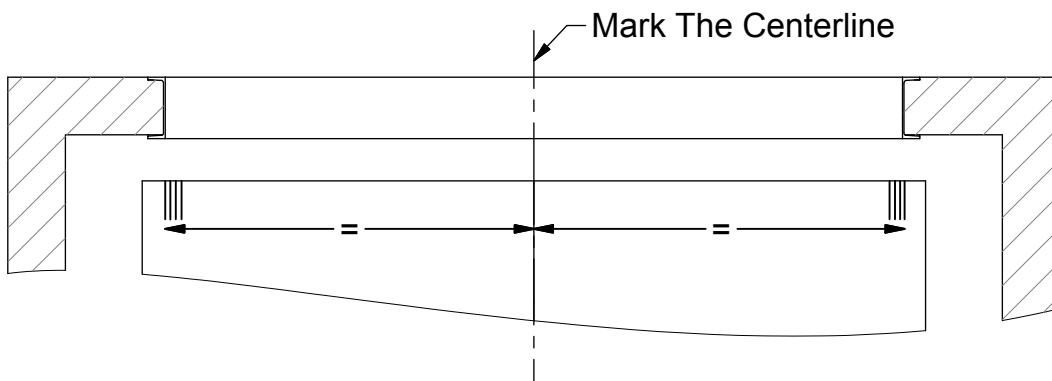

THE PEELLE COMPANY

FREIGHT DOORS | CAR GATES | CAR ENCLOSURES

TECHNICAL SUPPORT 1-800-787-5020 ext 275

12

Guide No. 267-EN
ATTENDANT OPERATED
ENTRANCE

Date: Oct 26/2020

10. LOCATING CENTER OF THE OPENINGS

770441-02



DBG = Distance Between Guides

10.1. POSITION THE CENTER OF THE GAUGE ROD ONTO THE AVERAGE OPENING CENTER LINE.

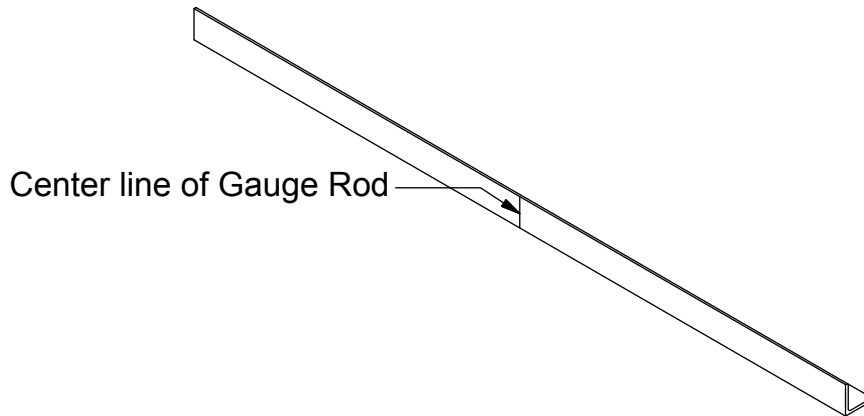

10.2. NEXT TRANSFER THE DBG TO THE PLATFORM.

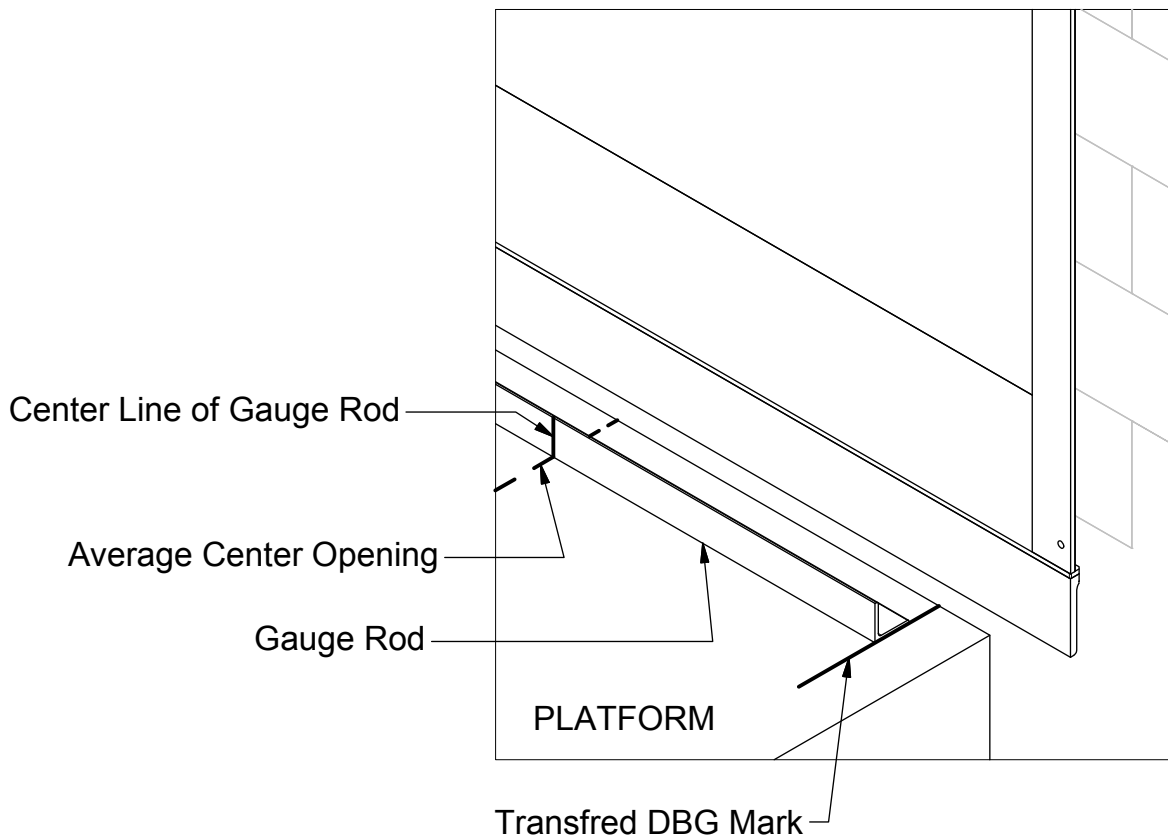

THE PEELLE COMPANY

FREIGHT DOORS | CAR GATES | CAR ENCLOSURES

TECHNICAL SUPPORT 1-800-787-5020 ext 275

13

Guide No. 267-EN
ATTENDANT OPERATED
ENTRANCE

Date: Oct 26/2020

11. BUILDING SILL LEVEL CHECK

770440-04

11.1. LEVEL THE SILL

Ensure Building Sill is Level +/- 3/8" [10mm]. If sill is out more than 3/8in [10mm] have sill corrected.

11.2. IDENTIFY LOWEST SIDE

Identify and mark the lowest side of the sill and project to opposite side of entrance.

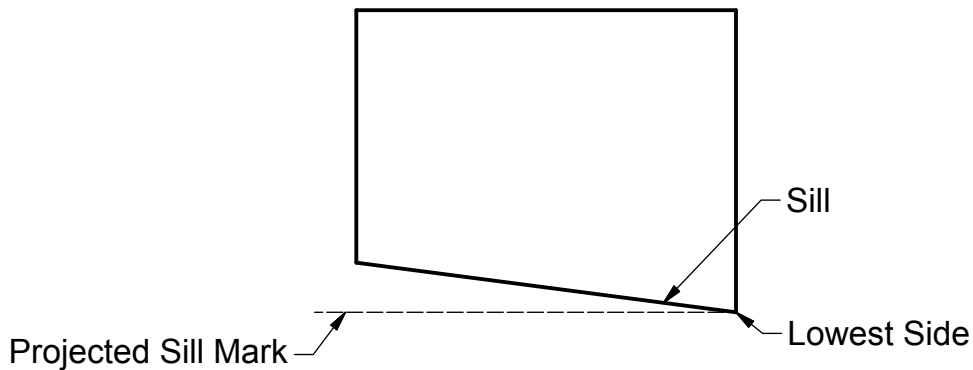

11.3. POSITION THE RAIL

When installing the first rail align the sill mark with the lowest side of the sill.



When installing the rail, align the sill mark with the lowest side of the sill (Projected Sill Mark).

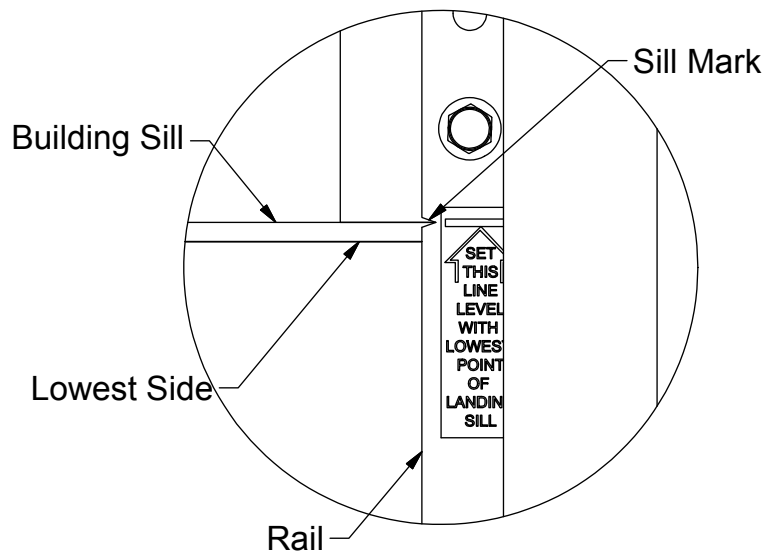

THE PELLE COMPANY

FREIGHT DOORS | CAR GATES | CAR ENCLOSURES

TECHNICAL SUPPORT 1-800-787-5020 ext 275

12. DOOR GUIDE RAIL INSTALLATION - OVERVIEW

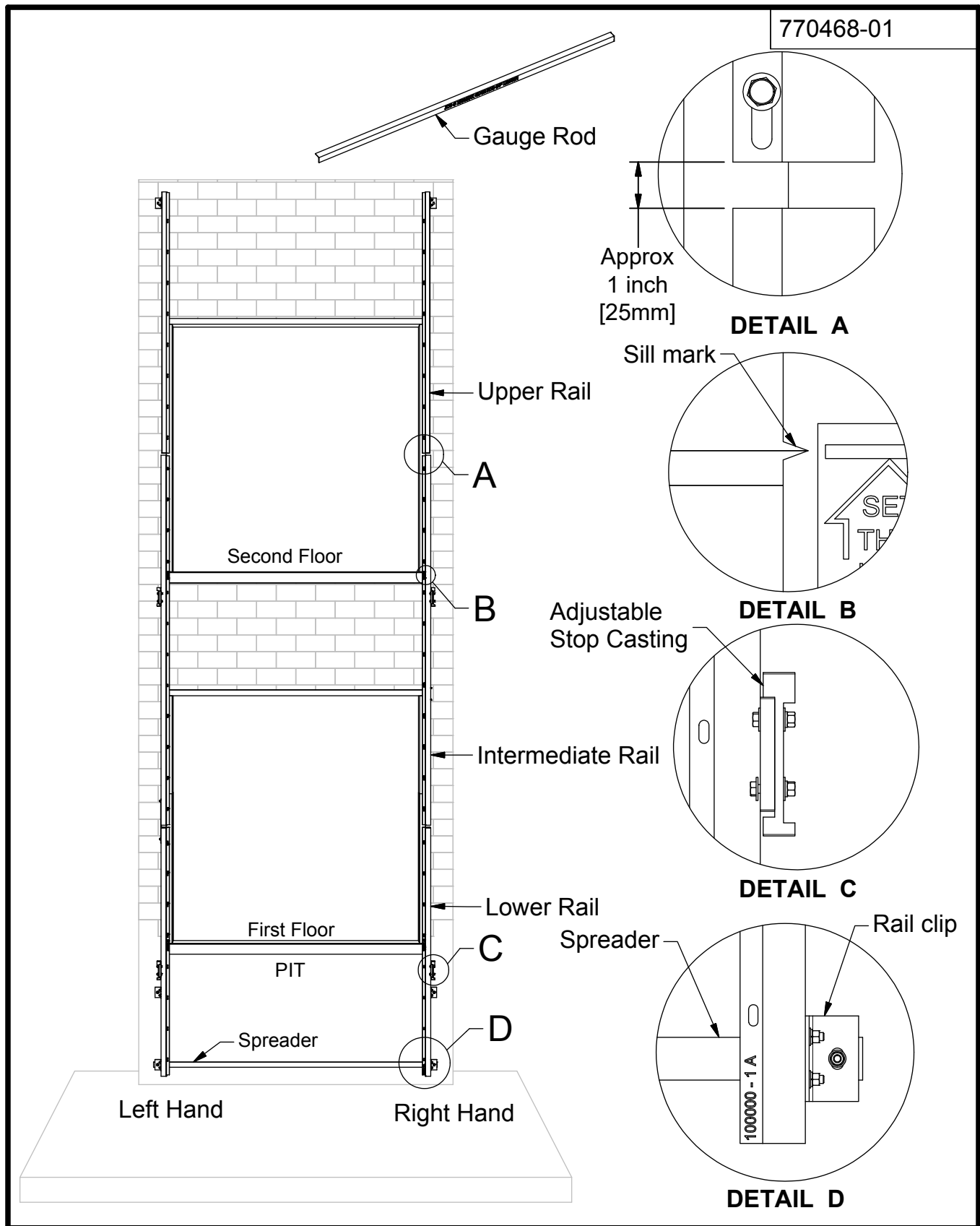

THE PELLE COMPANY

FREIGHT DOORS | CAR GATES | CAR ENCLOSURES
TECHNICAL SUPPORT 1-800-787-5020 ext 275

15

Guide No. 267-EN
ATTENDANT OPERATED
ENTRANCE

Date: Oct 26/2020

13. RAIL INSTALLATION POSITIONING

770446-02

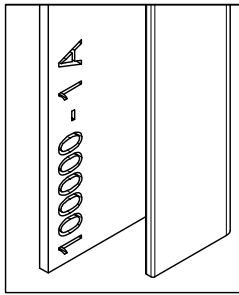

1. Locate job number and floor designation.

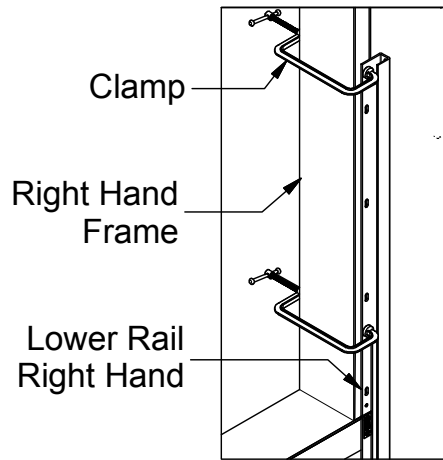

2. Clamp the lower rail to frame.

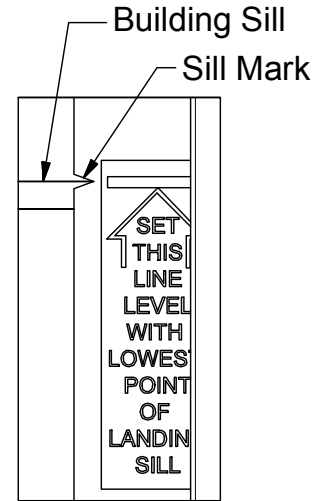

3. Set vertical position align sill mark with building sill.

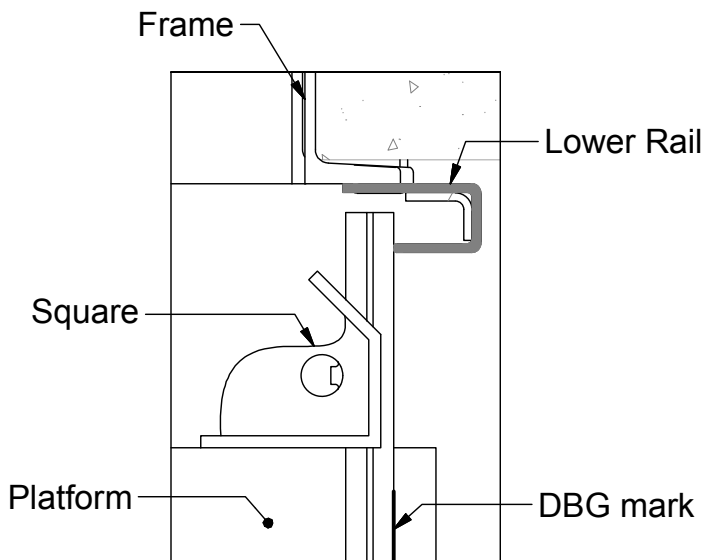

4. Align rail guide with DBG mark using set square



5. Ensure rails are set vertical using a level.



THE PEELLE COMPANY

FREIGHT DOORS | CAR GATES | CAR ENCLOSURES
TECHNICAL SUPPORT 1-800-787-5020 ext 275

14. RAIL BOLTING

770446-03

14.1. LOWEST RAIL BOLTING

- 1) Drill 1 1/32" [8.5mm] hole into steel entrance frame. Approximately 1/2in [13mm] deep. Avoid drilling into masonry wall. When drilling through rail slot ensure hole is in top of slot.
- 2) Drill 5/16in [8mm] hole into masonry wall. Approximately 1 1/2in [38mm] deep
- 3) Use 9/16" [14 mm] impact driver to install #06004 Rail Bolt. Do not use washers. Only install rail bolts into steel entrance frames.

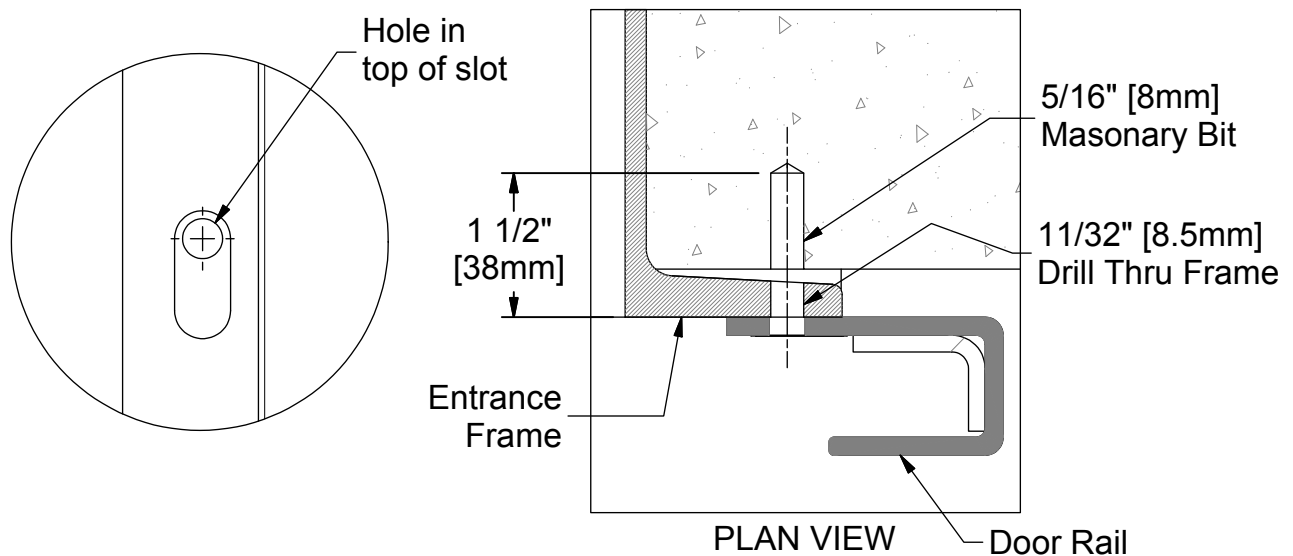

14.2. SHIM RAIL AS NECESSARY.

Refer back to "Car Clearance Check".

14.3. IN ORDER TO KEEP RAILS PLUMB AND MAINTAIN THE CORRECT CAR CLEARANCE USE "0629 RAIL SHIMS".

- 1) Loosen rail bolt
- 2) Hook the rail shim onto the rail bolt
- 3) Tighten rail bolt
- 4) Check rail is plumb



Maximum of 6 shims per bolt, If you require more than 6 shims weld flat bar to frame.

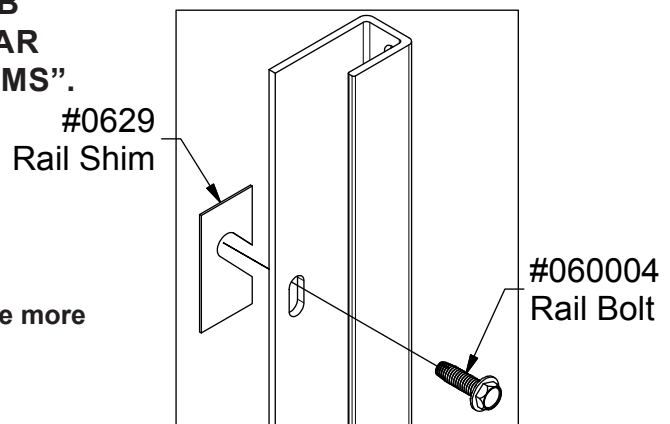

THE PEELLE COMPANY

FREIGHT DOORS | CAR GATES | CAR ENCLOSURES

TECHNICAL SUPPORT 1-800-787-5020 ext 275

17

Guide No. 267-EN
ATTENDANT OPERATED
ENTRANCE

Date: Oct 26/2020

15. HOW TO USE GAUGE ROD

770446-14

- The gauge rod is used to correctly space the left rail from the right rail, this will allow your door panel to fit perfectly between the rails and operate smoothly.
- After installing the right side rail position, clamp the left rail onto the entrance frame.
- Using the previous steps outlining dbg and sill mark, the left rail is in the correct location.
- Before drilling and bolting the left rail hold the gauge rod level between the two rail guides.
- Hold gauge rod level between the door rails.
- Slowly move the gauge rod up and down the rail, keeping the rod gauge level.

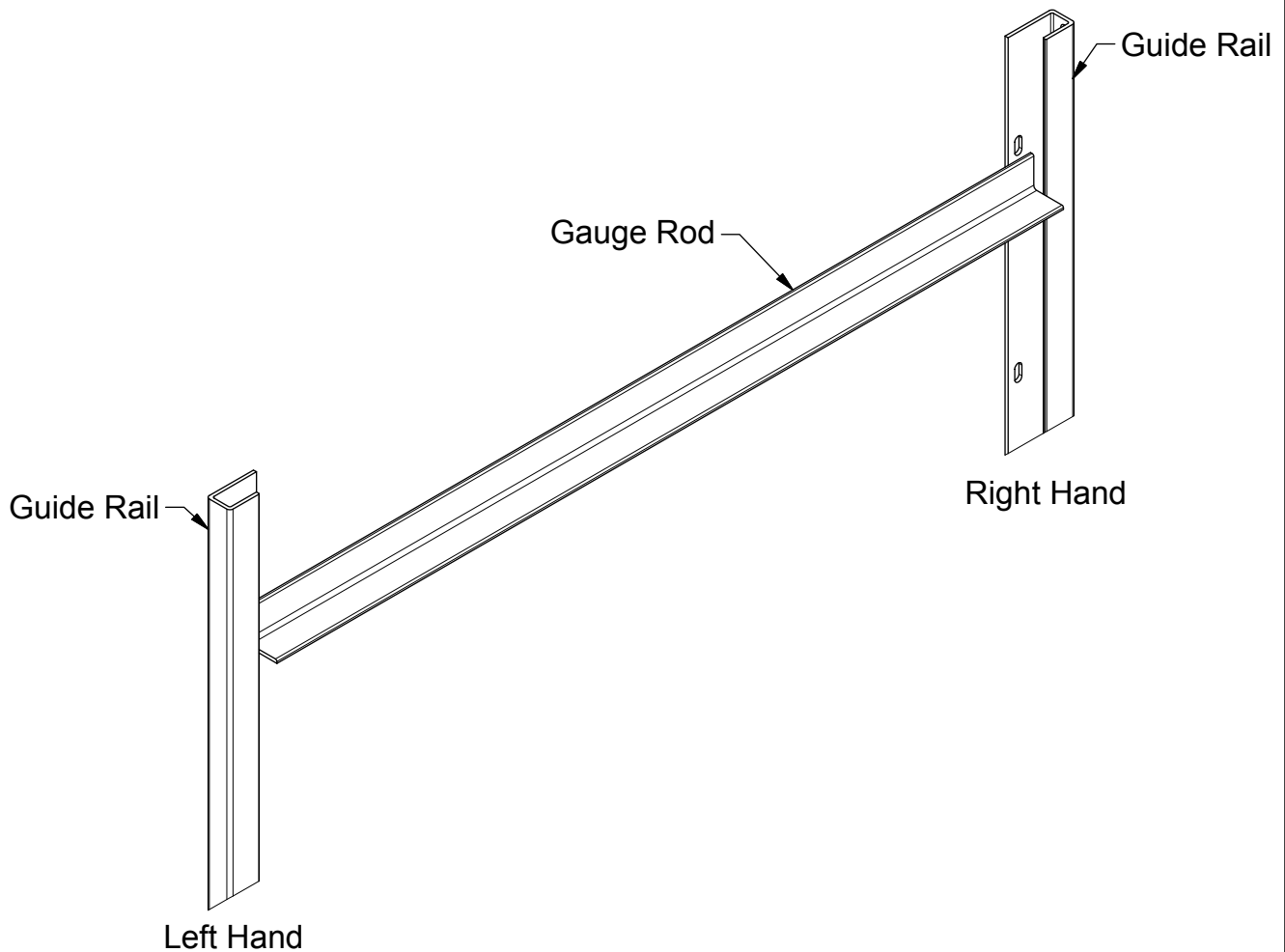

THE PEELLE COMPANY

FREIGHT DOORS | CAR GATES | CAR ENCLOSURES
TECHNICAL SUPPORT 1-800-787-5020 ext 275

18

Guide No. 267-EN
ATTENDANT OPERATED
ENTRANCE

Date: Oct 26/2020

16. RAIL INSTALLATION - OPPOSITE SIDE

770446-05

FOLLOW THESE STEPS FOR THE OPPOSITE SIDE RAIL INSTALLATION

- 1) Position opposite side (left rail) (*see pg 16, sec 13*).
- 2) Set vertical position for the lowest side level with opposite side (*see pg 16, sec 13*) step 3.
- 3) Ensure sill mark on left rail aligns with sill mark on the right rail.
- 4) Use gauge rod to ensure rails ARE CORRECT distance apart.
- 5) Drill and bolt rail into position.

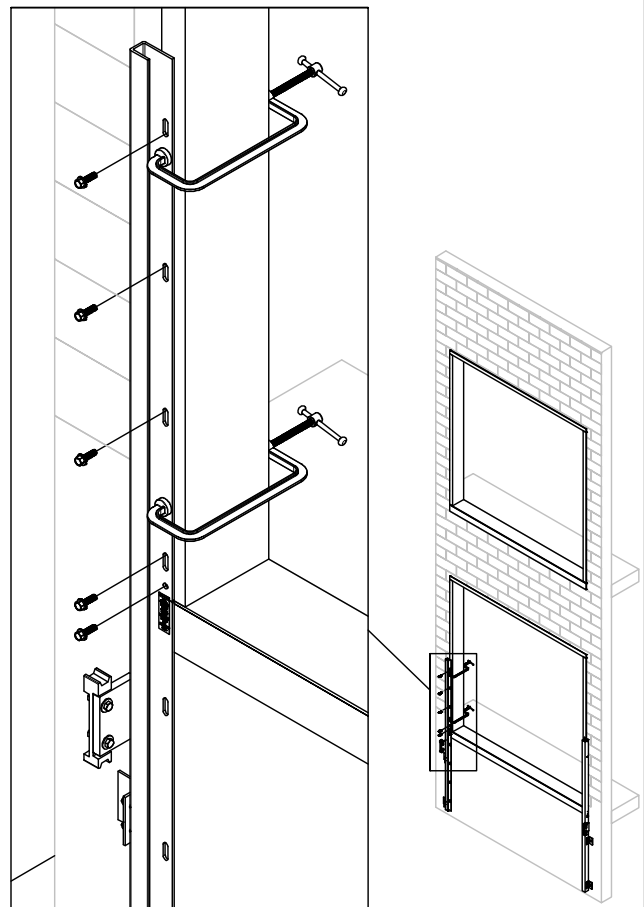
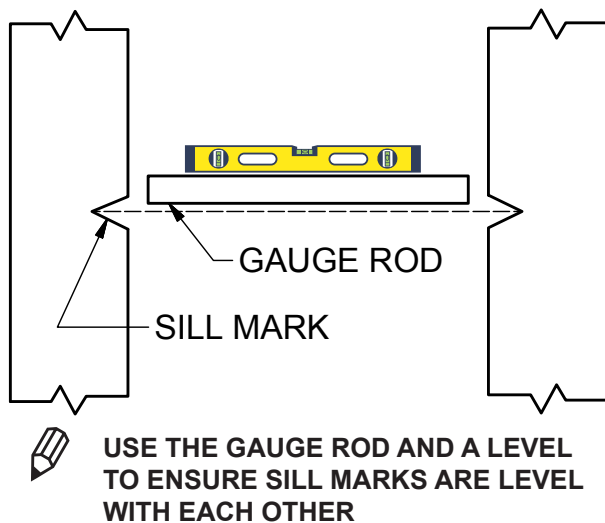

THE PELLE COMPANY

FREIGHT DOORS | CAR GATES | CAR ENCLOSURES
TECHNICAL SUPPORT 1-800-787-5020 ext 275

19

Guide No. 267-EN
ATTENDANT OPERATED
ENTRANCE

Date: Oct 26/2020

17. INTERMEDIATE OR TOP RAIL OVERVIEW

770468-27

THE NEXT RAIL TO INSTALL WILL BE EITHER THE INTERMEDIATE OR TOP RAIL.

INTERMEDIATE RAIL

Use Sill Mark to position Intermediate Rail with the Landing above.

TOP RAIL

Position the Top Rail 1" [25mm] above Lower Rail.

*Intermediate Rail
shared between two floors*

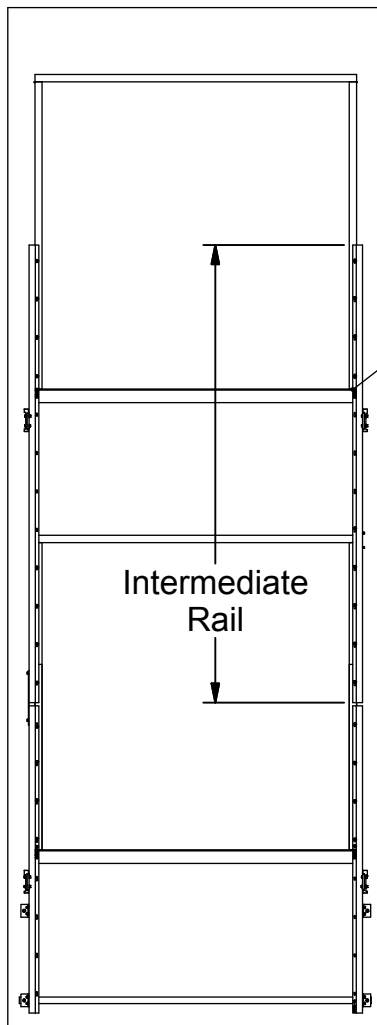

*Top Rail is not shared
between two floors*

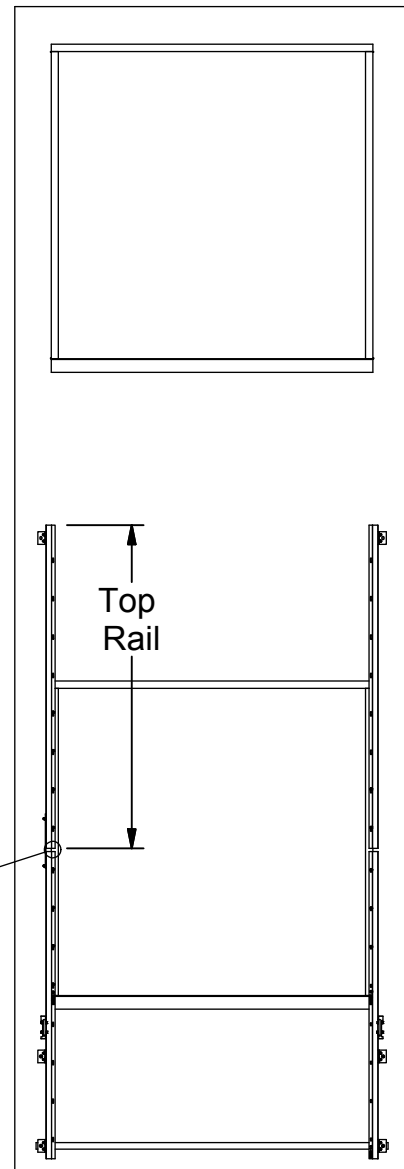

OR

1" [25mm]



THE PEELLE COMPANY

FREIGHT DOORS | CAR GATES | CAR ENCLOSURES

TECHNICAL SUPPORT 1-800-787-5020 ext 275

20

Guide No. 267-EN
ATTENDANT OPERATED
ENTRANCE

Date: Oct 26/2020

18. ATTACH CLIPS ANGLES TO WALL

770446-11

After all rails are installed, use gauge rod at top and bottom of rails to ensure correct distance apart is maintained.

Use masonry anchor bolts to secure rails to wall, wherever rail clips are provided.



For sealed waterproof pits, use spreader between rails instead of wall anchors.

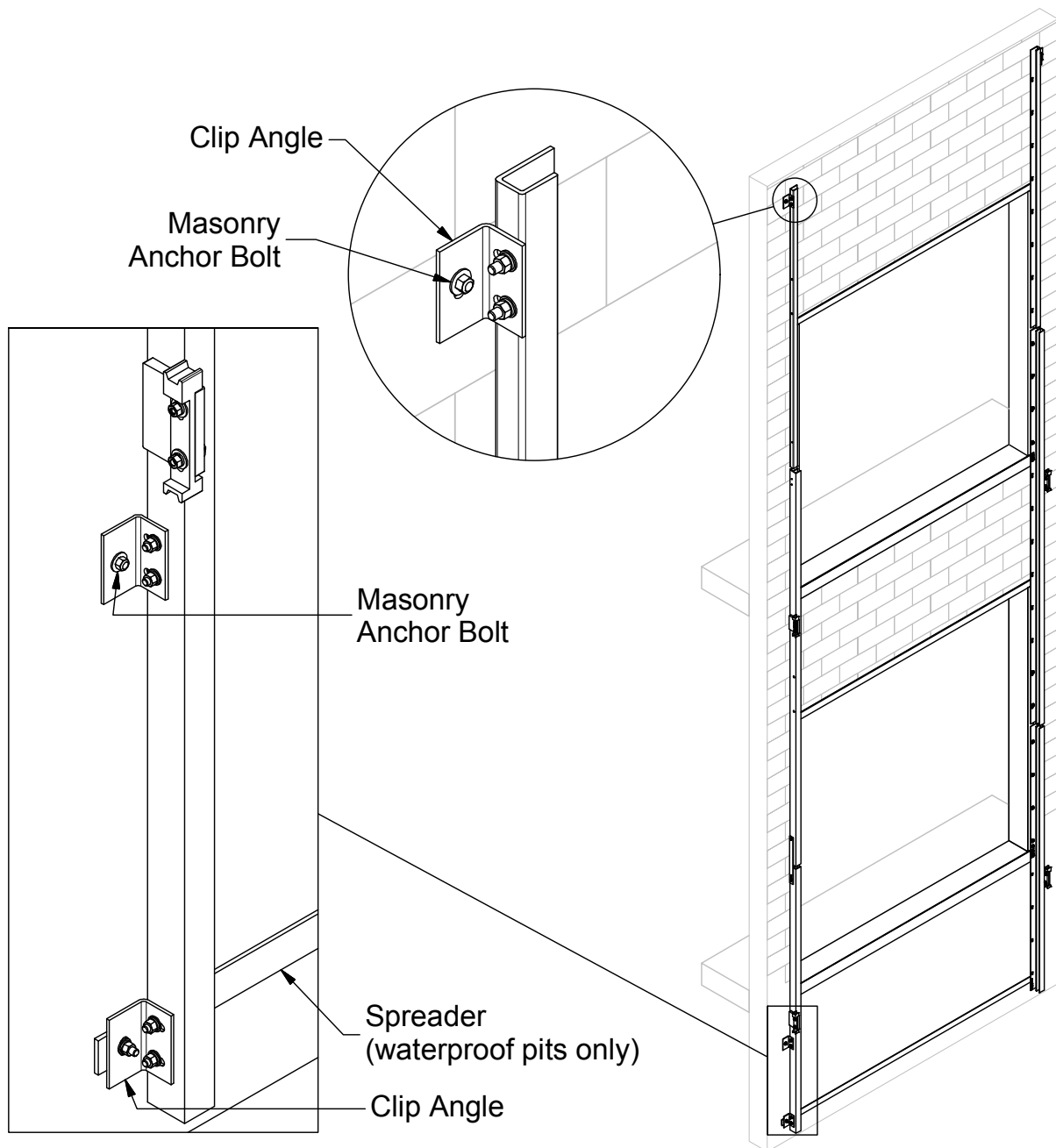

THE PEELLE COMPANY

FREIGHT DOORS | CAR GATES | CAR ENCLOSURES

TECHNICAL SUPPORT 1-800-787-5020 ext 275

21

Guide No. 267-EN
ATTENDANT OPERATED
ENTRANCE

Date: Oct 26/2020

19. COMPONENT INSTALLATION

19.1. MANUAL SHEAVES

770147-31

- 1) Position sheaves forward in slots for regular and extended sill doors. For pass doors position the operators back on the slot.
- 2) Tighten bolts, adjustments will be made later.



When rails are tapped for operators use 3/4" long bolts

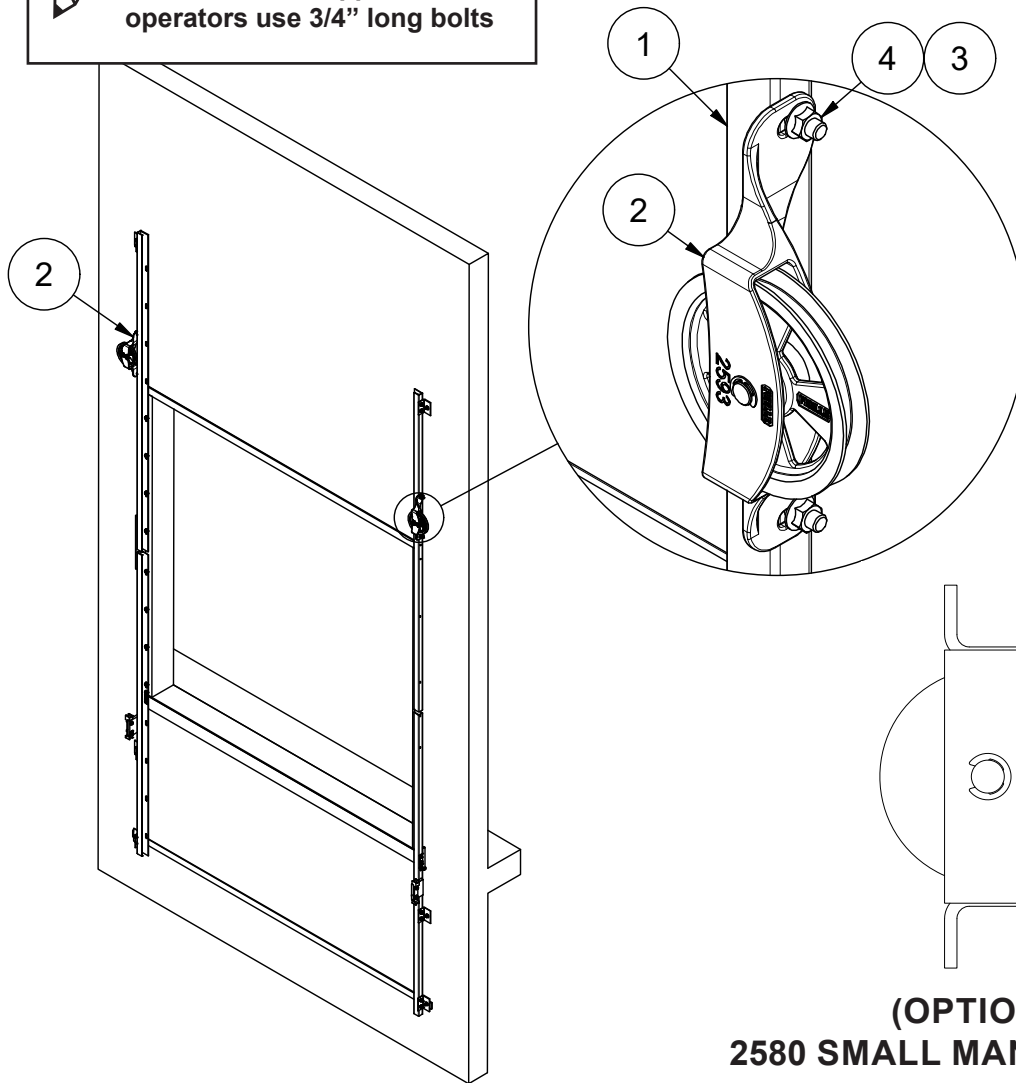

(OPTIONAL)
2580 SMALL MANUAL SHEAVE

4	2	1137345	1/2-13 HEX SERRATED FLANGE NUT
3	2	110120379	1/2"-13 x 1 1/4" Lg HEX HD BOLT ZP
2	2	2593	SHEAVE ASSY, 6 1/2"
1	1	770145	RIGHTHAND RAIL ASSY
ITEM	QTY	PART NO	DESCRIPTION



THE PEELLE COMPANY

FREIGHT DOORS | CAR GATES | CAR ENCLOSURES
TECHNICAL SUPPORT 1-800-787-5020 ext 275

19.2. PLUG ROD INSTALLATION

770147-32

- 1) Insert plug rod into plug proof trigger as shown.
- 2) Tighten the rod plate item 3 to the trigger item 2



The position of the plug rod will be made later.

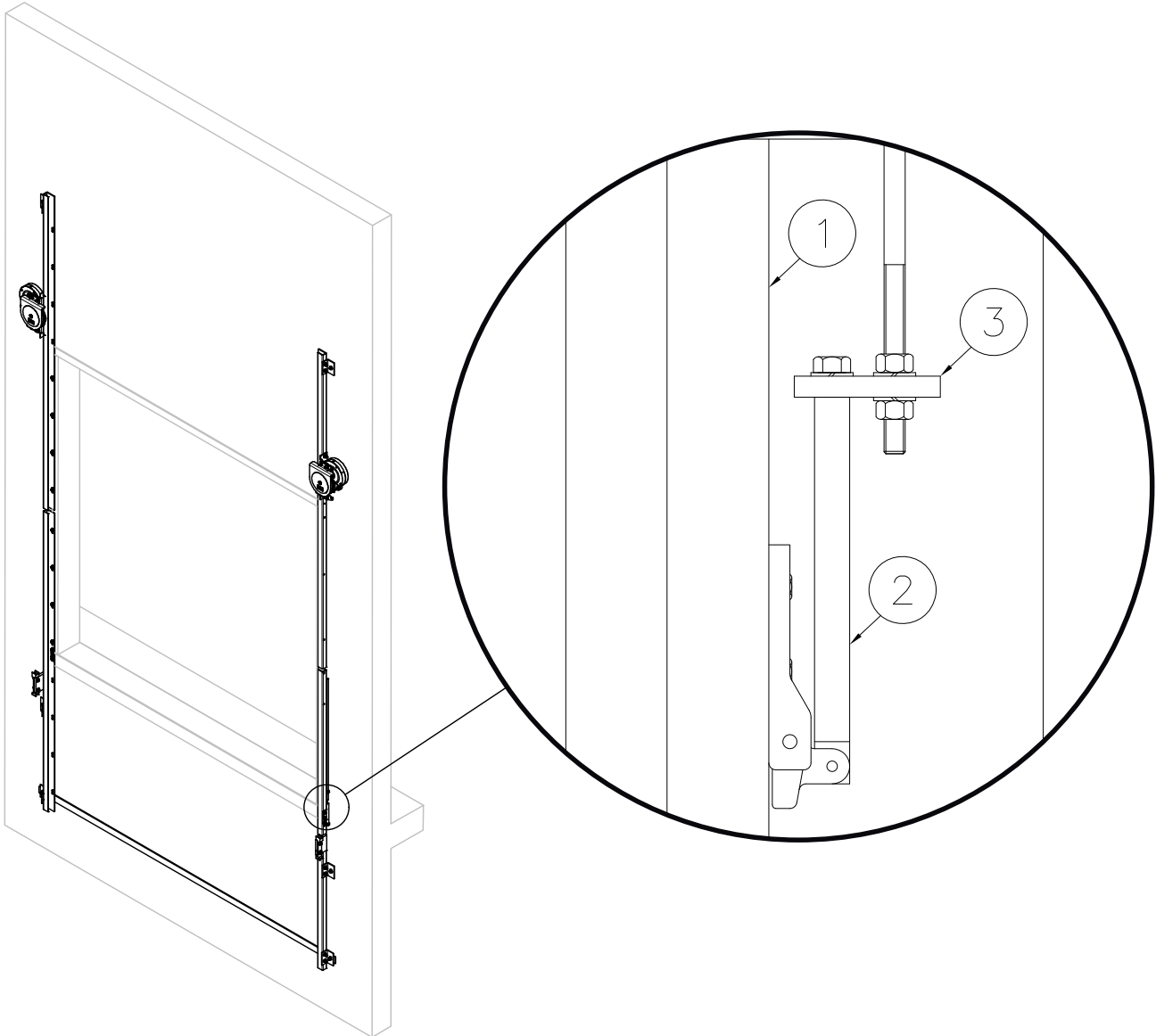

3	1	DS8	PLUG ROD ASSY
2	1	23561	PLUG PROOF TRIGGER ASSY
1	1	770142	RIGHT HAND RAIL ASSY
ITEM	QTY	PART NO	DESCRIPTION



THE PEELLE COMPANY

FREIGHT DOORS | CAR GATES | CAR ENCLOSURES

TECHNICAL SUPPORT 1-800-787-5020 ext 275

23

Guide No. 267-EN
ATTENDANT OPERATED
ENTRANCE

Date: Oct 26/2020

19.3. RO INTERLOCK INSTALLATION

770147-37

- 1) Insert plug rod into bottom of interlock.
- 2) Align interlock slots with pre-drilled holes in rail.
- 3) Loosely tighten the bolts. Vertical position of interlock will be set later.

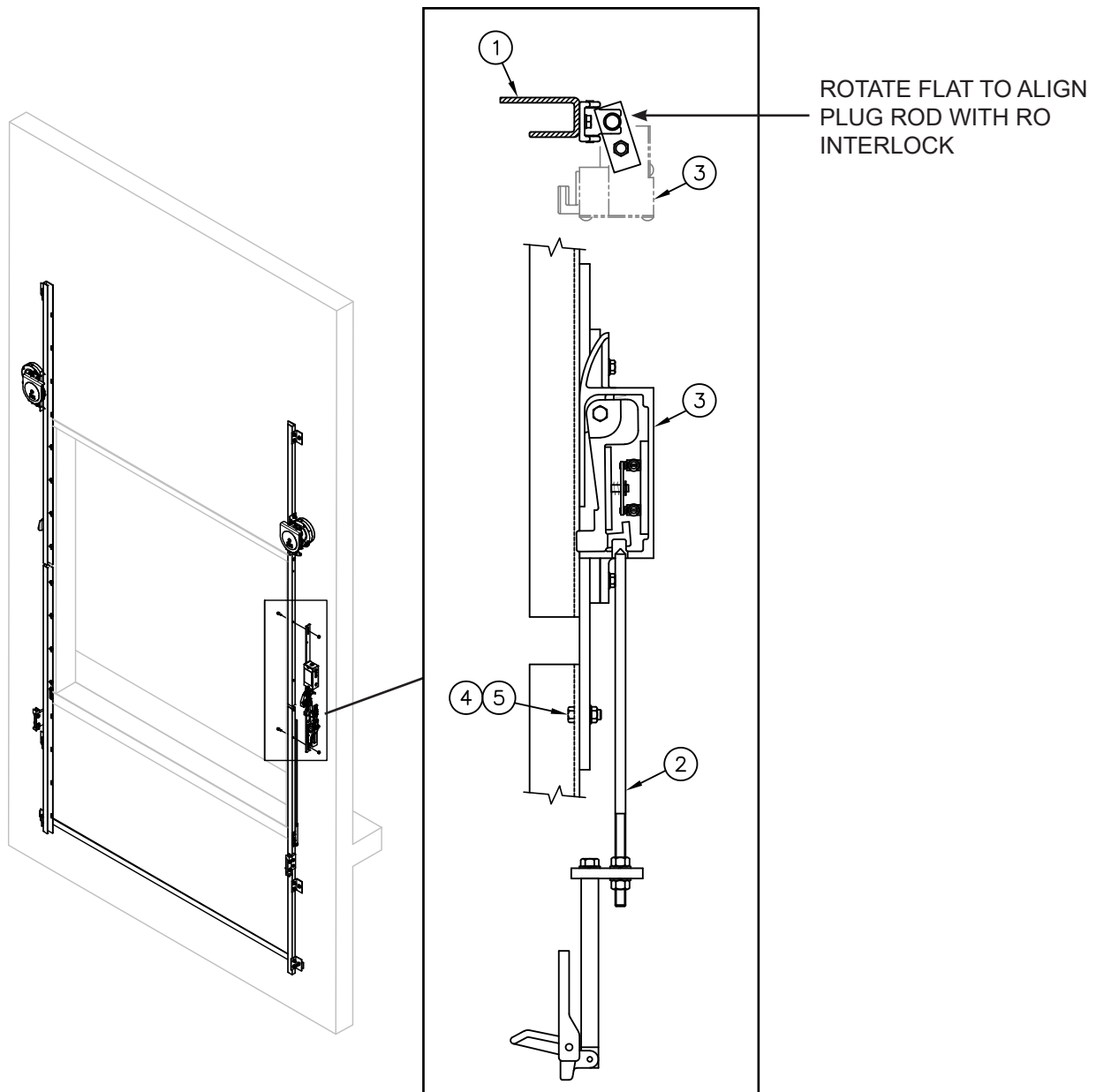

5	2	97244	3/8-16 SERRATED FLANGE NUT Z
4	1	800061	3/8-16 x 1 HH BOLT ZP
3	1	DS10	RO INTERLOCK AND MOUNTING PLATE ASSY
2	1	DS8	PLUG ROD ASSY
1	1	770145	RIGHTHAND RAIL ASSY
ITEM	QTY	PART NO	DESCRIPTION



THE PEELLE COMPANY

FREIGHT DOORS | CAR GATES | CAR ENCLOSURES

TECHNICAL SUPPORT 1-800-787-5020 ext 275

24

Guide No. 267-EN
ATTENDANT OPERATED
ENTRANCE

Date: Oct 26/2020

19.4. SPLICE PLATE & PARKING DEVICE (MECHANICAL LOCK)

770147-04

► Install splice plate or parking device

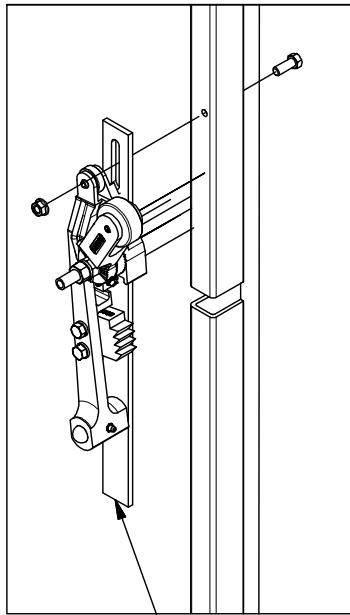

0354
Mechanical Lock (option)

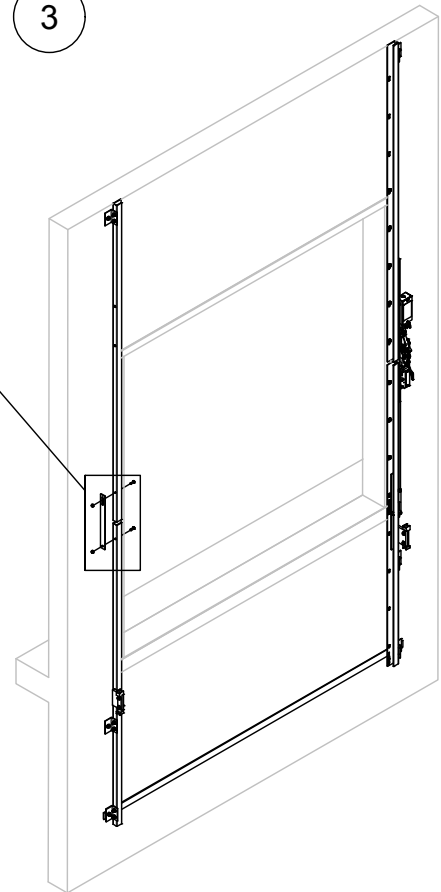
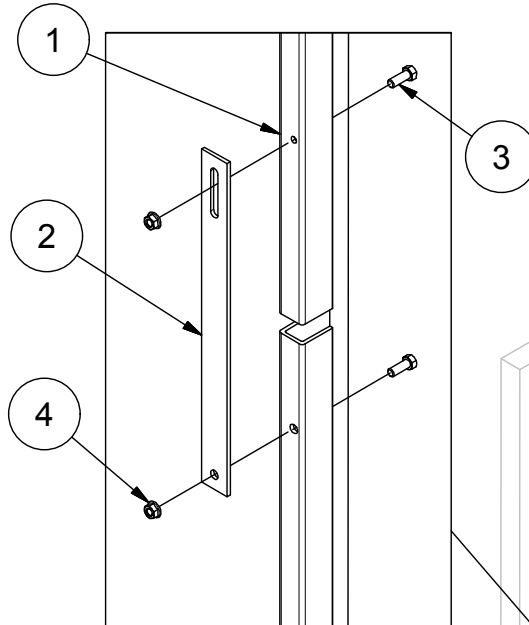

4	3	97244	3/8-16 SERRATED FLANGE NUT Z
3	4	800061	3/8-16 x 1 HH BOLT ZP
2	1	035047	SPLICE PLATE
1	1	770235	LEFTHAND RAIL ASSY
ITEM	QTY	PART NO	DESCRIPTION



THE PELLE COMPANY

FREIGHT DOORS | CAR GATES | CAR ENCLOSURES

TECHNICAL SUPPORT 1-800-787-5020 ext 275

25

Guide No. 267-EN
ATTENDANT OPERATED
ENTRANCE

Date: Oct 26/2020

19.5. BAR KEEPER

770147-35

- 1) Loosely tighten the bolts. Vertical position of Bar Keeper will be set later.

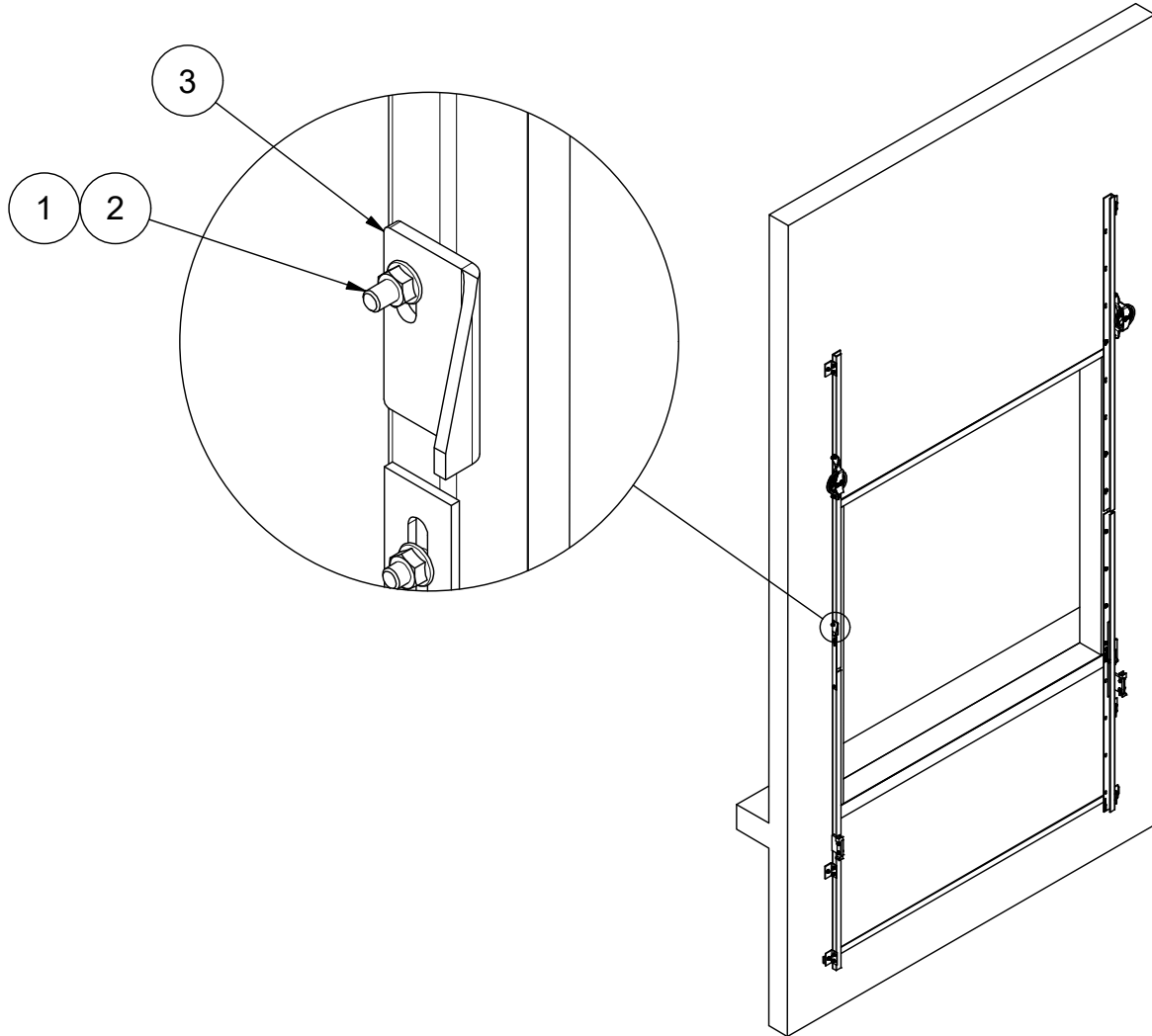

3	1	DS3	BAR KEEPER
2	2	110120345	3/8-16 X 1 1/4 HEX HD BOLT
1	2	97244	3/8-16 SERRATED FLANGE NUT Z
ITEM	QTY	PART NO	DESCRIPTION



THE PEELLE COMPANY

FREIGHT DOORS | CAR GATES | CAR ENCLOSURES

TECHNICAL SUPPORT 1-800-787-5020 ext 275

26

Guide No. 267-EN
ATTENDANT OPERATED
ENTRANCE

Date: Oct 26/2020

20. PANEL INSTALLATION

770804-02

20.1. INSTALL A HOIST OR CHAIN FALL

- Mount the chain fall directly to the hoistway wall above the opening.
- Center hoist above the opening
- Mount hoist high enough to lift upper panel to open position (i.e. $> 1 \frac{1}{2}$ Opening height from the floor)

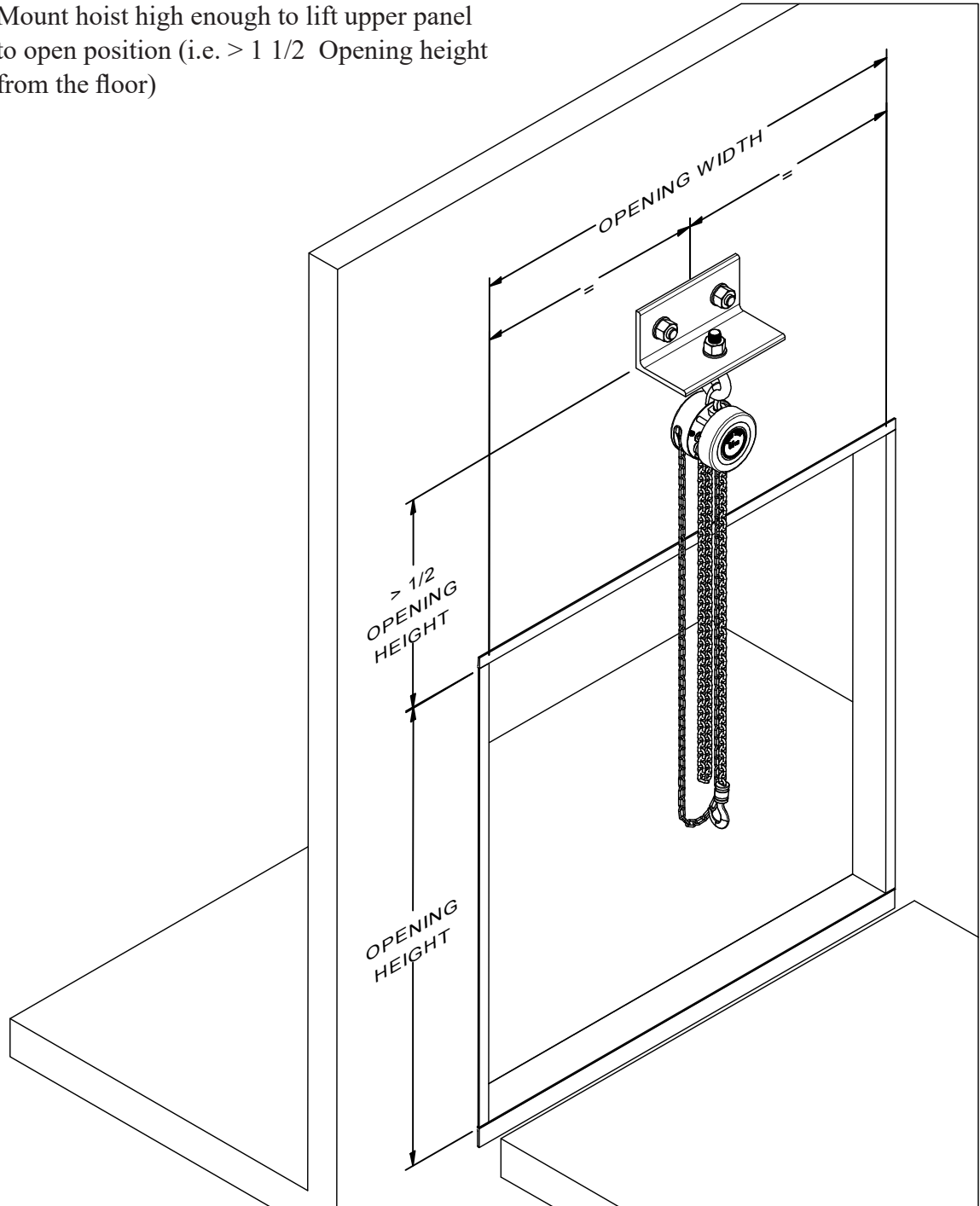

THE PEELLE COMPANY

FREIGHT DOORS | CAR GATES | CAR ENCLOSURES

TECHNICAL SUPPORT 1-800-787-5020 ext 275

27

Guide No. 267-EN
ATTENDANT OPERATED
ENTRANCE

Date: Oct 26/2020

20.2. POSITION PANEL CRATE AND CONNECT STRAPS

770804-04

- Locate the correct panel for the opening.
- All panels are marked on the shoebar with the Job Number and floor designation
- Center the crate in the opening.
- Secure two straps to the panel.
- Use the choke method.
- Connect each strap to the chain fall.

Peelle Job Number and
Floor Designation

100000 - 1 A
Line A Front
Line C Rear
Floor Designation
Peelle Job Number

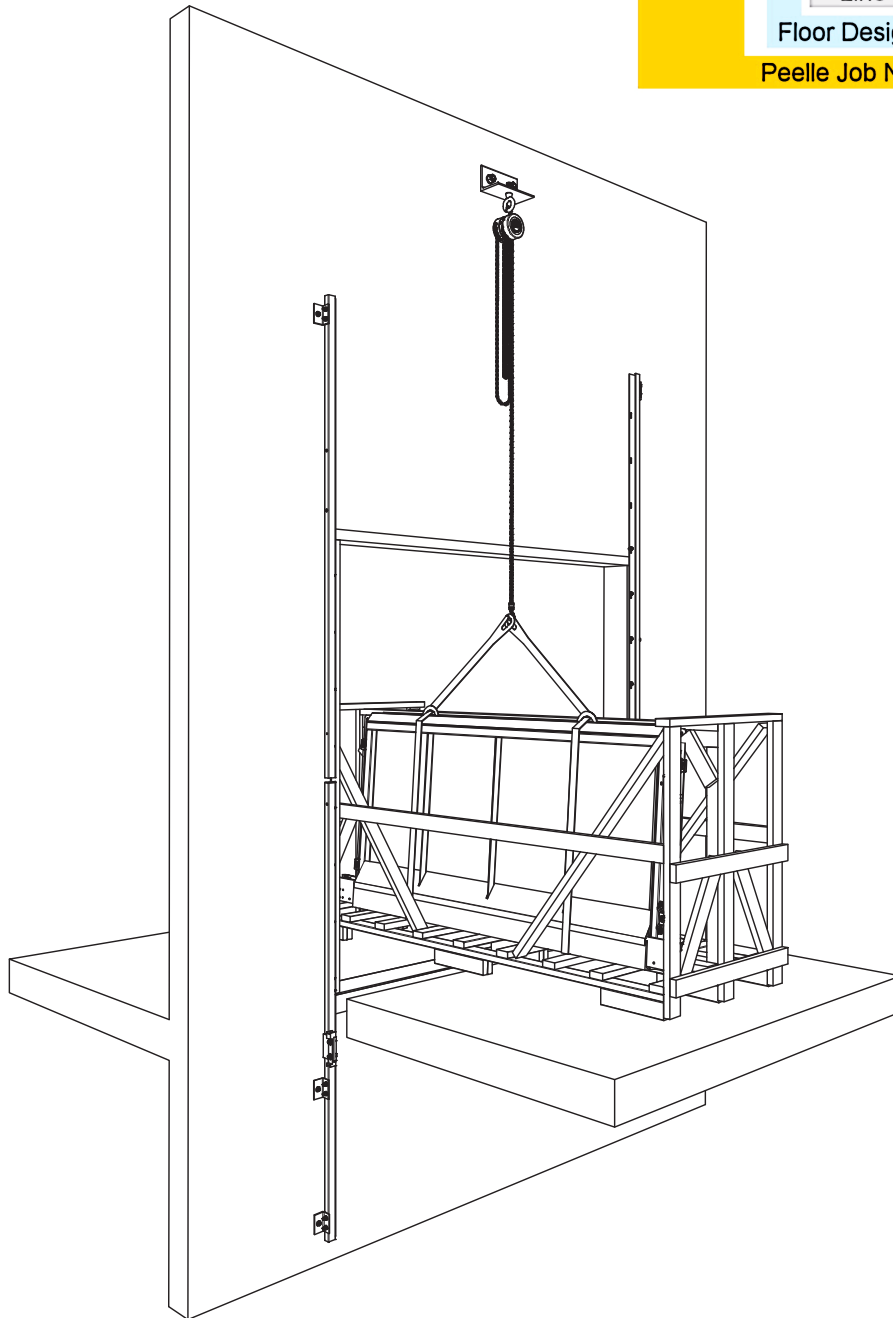
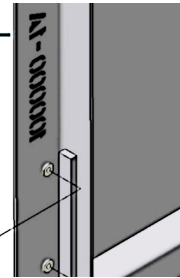

THE PEELLE COMPANY

FREIGHT DOORS | CAR GATES | CAR ENCLOSURES

TECHNICAL SUPPORT 1-800-787-5020 ext 275

28

Guide No. 267-EN
ATTENDANT OPERATED
ENTRANCE

Date: Oct 26/2020

20.3. LIFT PANEL AND REMOVE CRATE

770804-05

- Hoist panel off the crate.
 - Remove the crate from the opening.
 - Position two support blocks on floor.
-  #0606 Door Dolly may be required to help position panel.



0606 DOOR DOLLY

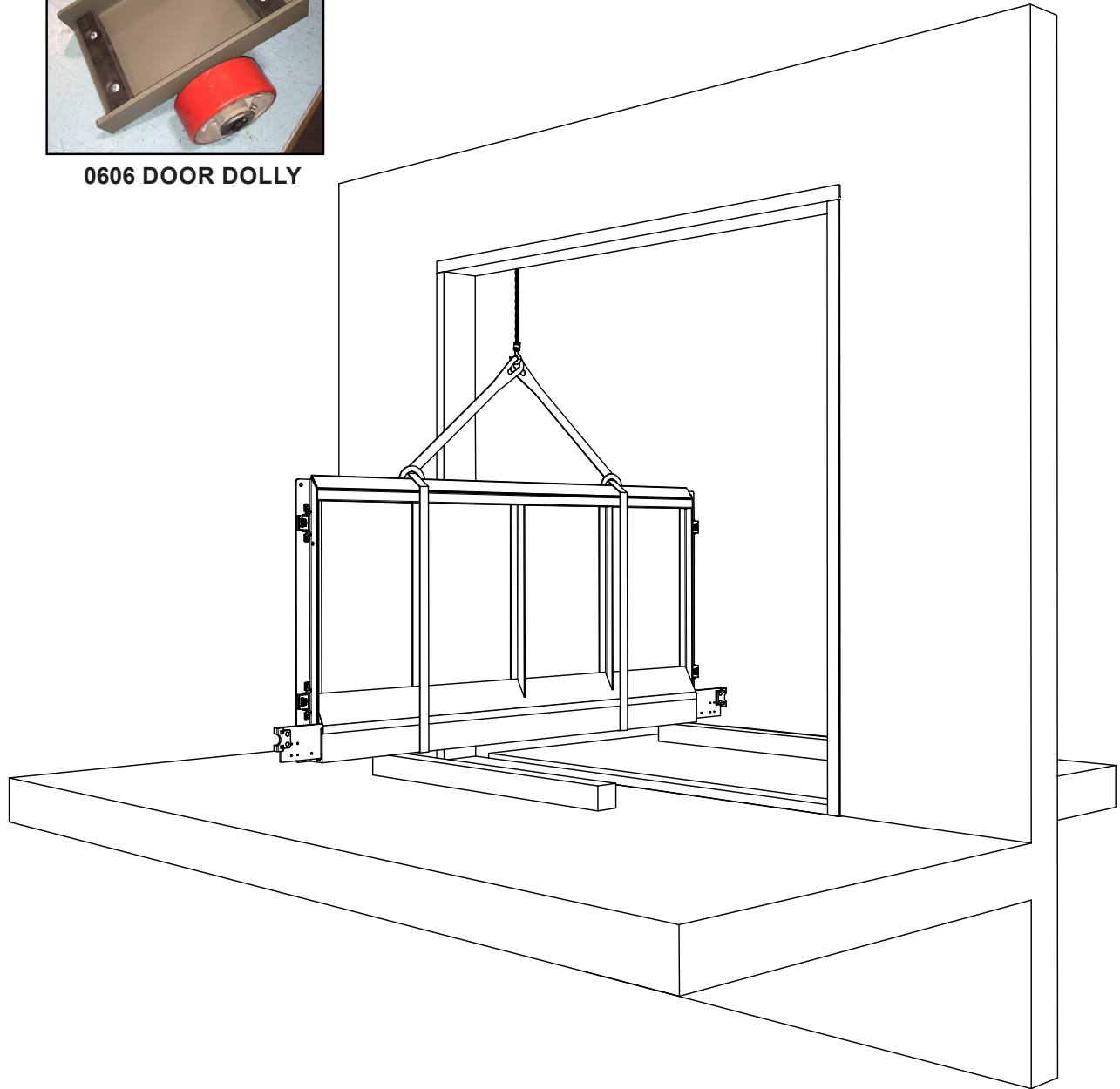

THE PEELLE COMPANY

FREIGHT DOORS | CAR GATES | CAR ENCLOSURES

TECHNICAL SUPPORT 1-800-787-5020 ext 275

20.4. ROTATE THE PANEL

770804-06



Panels are shipped upside down (heavy side down)

- Lower the panel onto the blocks.
- Reposition the straps, to pickup from the top of the panel.
- Lift the panel into the upright position.
- Lift panel to upright position.

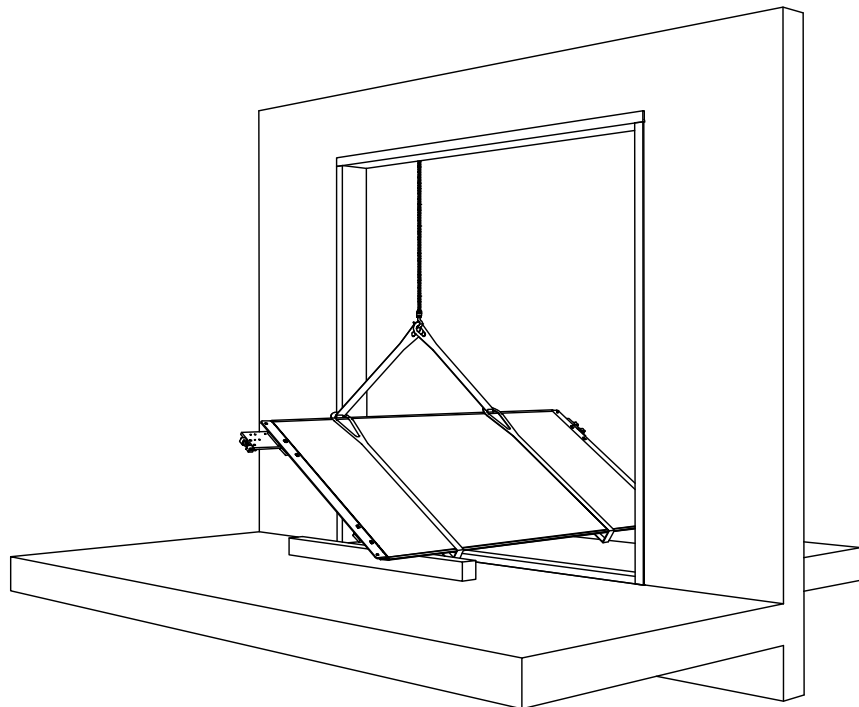
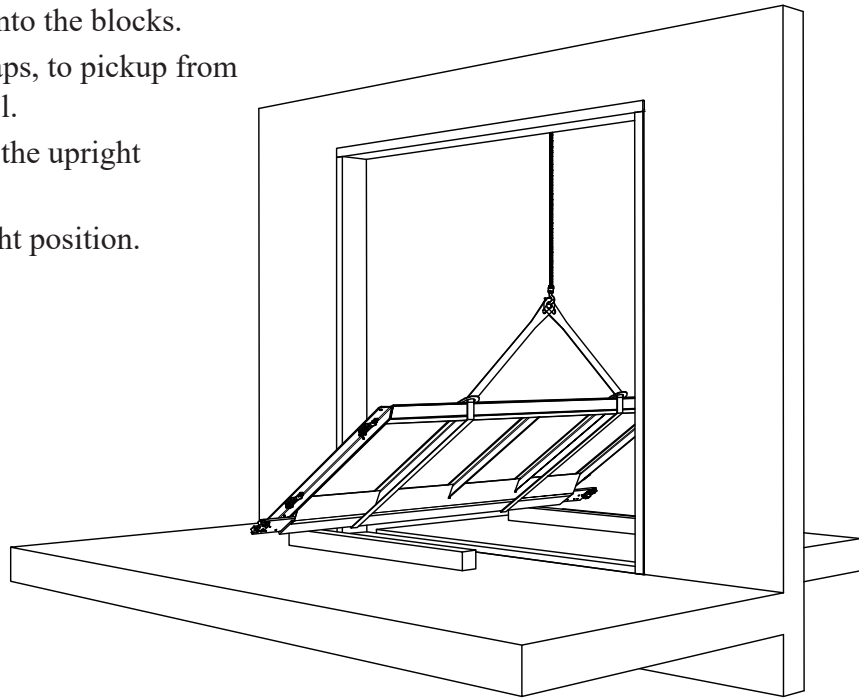

THE PEELLE COMPANY

FREIGHT DOORS | CAR GATES | CAR ENCLOSURES

TECHNICAL SUPPORT 1-800-787-5020 ext 275

30

Guide No. 267-EN
ATTENDANT OPERATED
ENTRANCE

Date: Oct 26/2020

20.5. HOIST THE PANEL INTO POSITION

770804-08

- Hoist the panel into position ready for insertion into landing door rails.

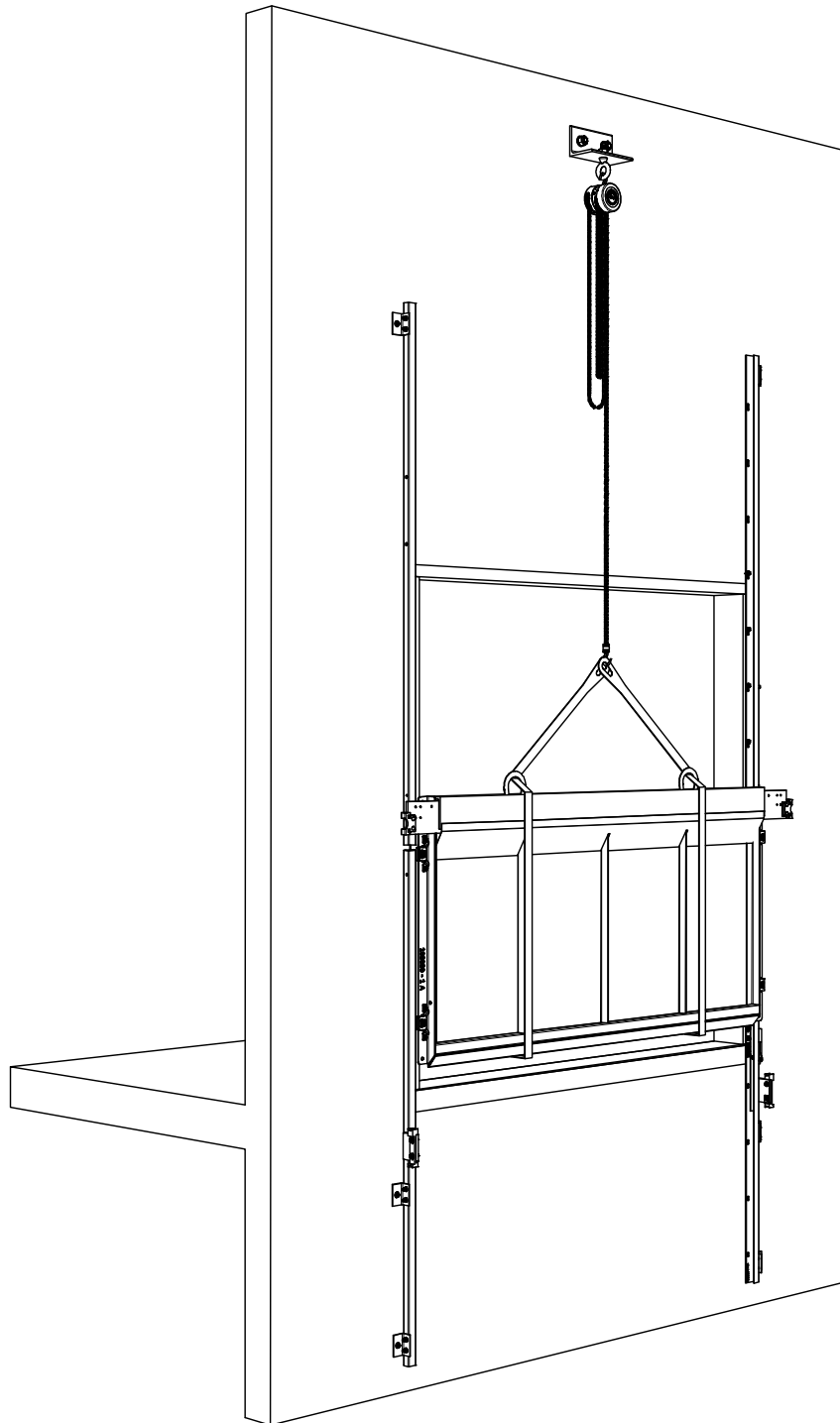

THE PEELLE COMPANY

FREIGHT DOORS | CAR GATES | CAR ENCLOSURES

TECHNICAL SUPPORT 1-800-787-5020 ext 275

31

Guide No. 267-EN
ATTENDANT OPERATED
ENTRANCE

Date: Oct 26/2020

20.6. INSTALL THE LOWER DOOR PANEL

- Remove shoes from the small shoebar (one side of the panel)
- Position the lower panel inside the landing door rails.
- Engage the shoes.
- Re-attach the shoes on the opposite side.
- Lower the panel to rest on the door stops.
- Remove the straps.

Peelle Job Number and Floor Designation

100000 - 1 A
 Line A Front
 Line C Rear
 Floor Designation
 Peelle Job Number

Remove shoes on small shoebar side.

Note:
 Re-attach shoes to the same location.

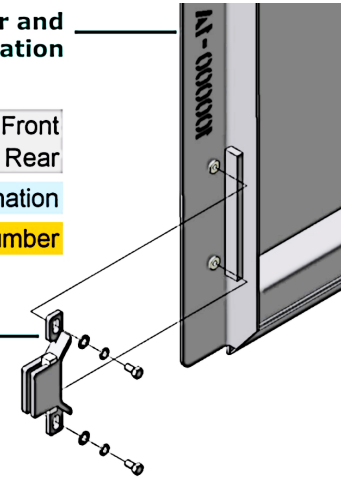

Shoes Removed

Plan of door panel fitting in between rails
 Use this method for upper and lower panels

Slide the small shoebar into the rail. Swing the large shoebar side into the rail and engage shoe into guide. Slide the removed shoes into place and re-attach.

PLAN VIEW SHOWING LOWER PANEL

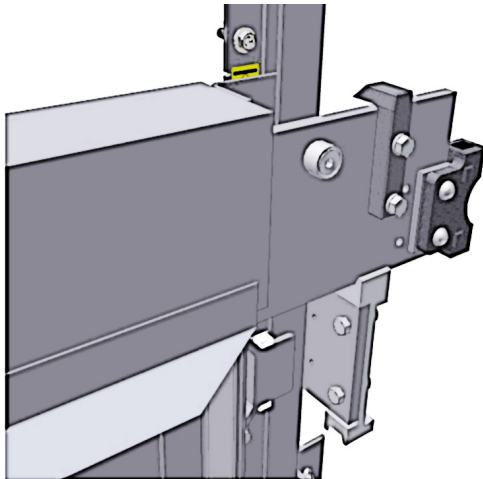

Rest the lower door panel on the door stops



THE PEELLE COMPANY

FREIGHT DOORS | CAR GATES | CAR ENCLOSURES
 TECHNICAL SUPPORT 1-800-787-5020 ext 275

20.7. INSTALL THE UPPER DOOR PANEL

- Remove shoes from the small shoebar (one side of the panel)
- Position the upper panel inside the landing door rails.
- Engage the shoes.
- Re-attach the shoes on the opposite side.
- Raise the panel to the full open position and hold in place.



When installing the upper panel determine what type of upper panel you have.

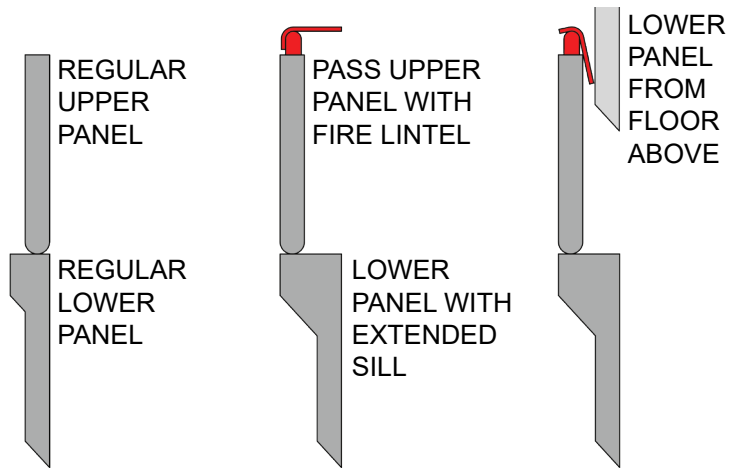

Remove shoes from one side

Note:
Re-attach shoes to the same location.

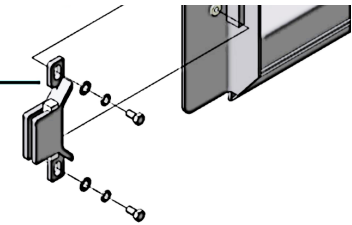

SWING THE SHOEBAR INTO THE RAIL AND ENGAGE THE SHOE ONTO THE GUIDE. RE-ATTACH THE SHOES.

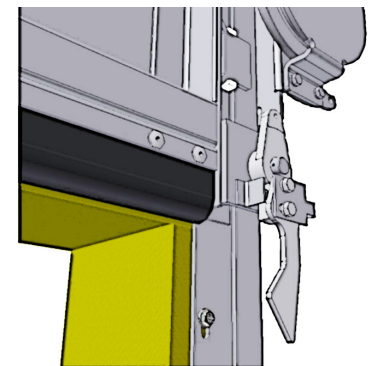
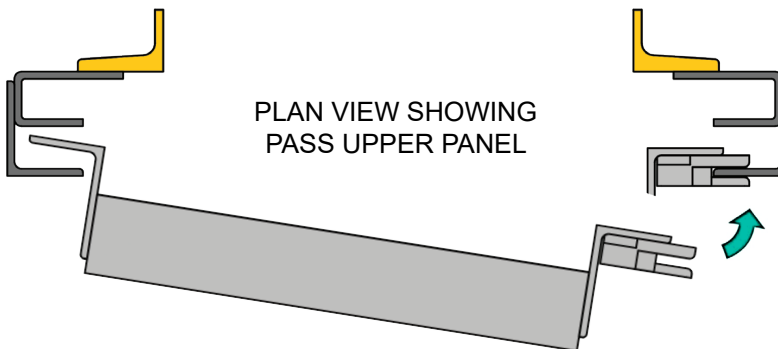
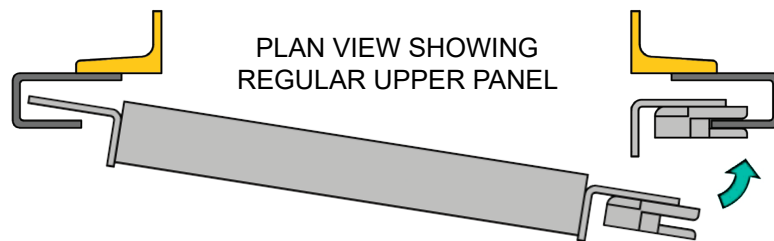

Hoist the upper door panel into the full open position. **Hold in place**



THE PEELLE COMPANY

FREIGHT DOORS | CAR GATES | CAR ENCLOSURES
TECHNICAL SUPPORT 1-800-787-5020 ext 275

33

Guide No. 267-EN
ATTENDANT OPERATED
ENTRANCE

Date: Oct 26/2020

21. HANGING THE PANELS

21.1. CHAIN OVERVIEW - REGULAR BI-PARTING

CHAIN PATH

- Connect chain to lower panel chain rod and feed chain up and over the operator sheave and down to the tension latch.

CONNECTIONS

- Connect the chain link with the spring clip legs facing down.
- Use tie-wraps to securely hold the chain link assembly together.
- Double check connections and remove hoisting straps.
- Two chinas required for Biparting doors

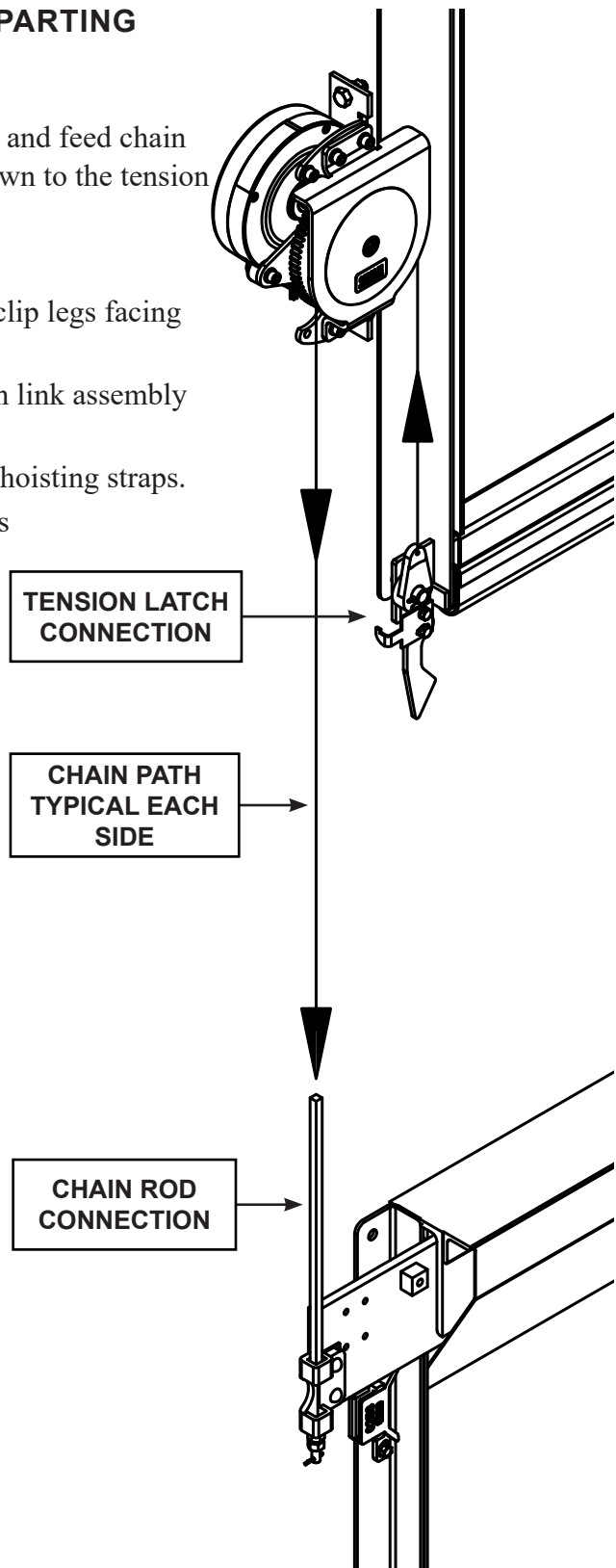

THE PEELLE COMPANY

FREIGHT DOORS | CAR GATES | CAR ENCLOSURES

TECHNICAL SUPPORT 1-800-787-5020 ext 275

34

Guide No. 267-EN
ATTENDANT OPERATED
ENTRANCE

Date: Oct 26/2020

21.2. INSTALL THE TENSION LATCH

770147-23

- 1) Insert the Tension Latch Assy (add a bit of oil).
- 2) Insert spring pin and make sure it fits tightly.
- 3) Install the hook and auxiliary lock components.

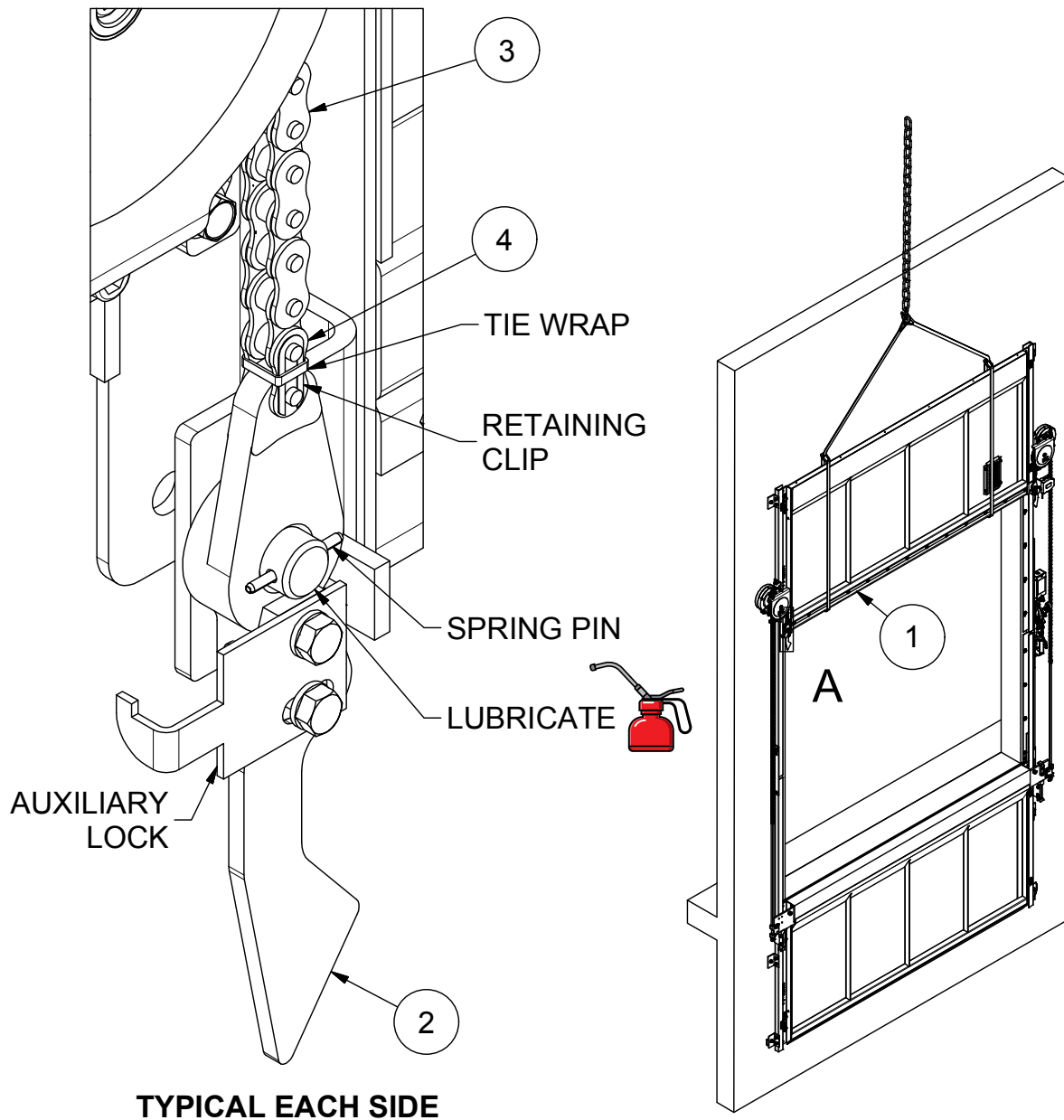

4	4	01801	CONNECTION LINK
3	2	01807	DOOR CHAIN
2	1	06696	SIDE LATCHING ASSEMBLY
1	1	770105	REGULAR UPPER PANEL
ITEM	QTY	PART NO	DESCRIPTION



THE PELLE COMPANY

FREIGHT DOORS | CAR GATES | CAR ENCLOSURES
TECHNICAL SUPPORT 1-800-787-5020 ext 275

35

Guide No. 267-EN
ATTENDANT OPERATED
ENTRANCE

Date: Oct 26/2020

21.3. INSTALL THE CHAIN ROD

770147-24

- 1) Insert the chain rod into the rod clip on the hangerbar.
- 2) Screw on the nuts, lock washer and cotter pin.
- 3) Lower nuts all the way to bottom of the rod for full adjustment.
- 4) Hold rod in place using vice grips (see image below).
- 5) Cut and connect the chain.

 When installing chains you may need to cut off a few links if chain is too long. Use the Peelle P/N 0608 Chain Pin Extractor.

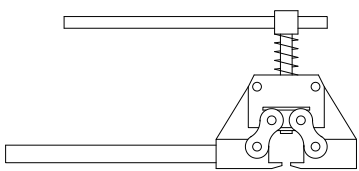
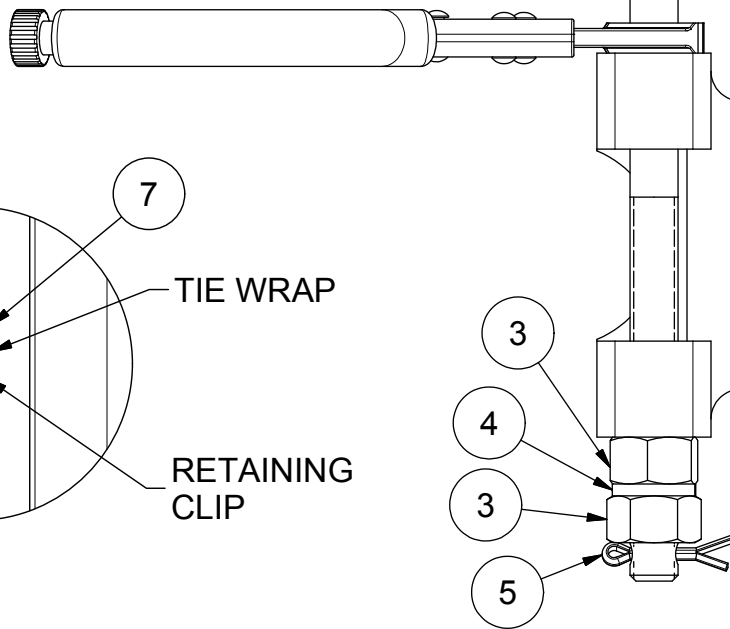
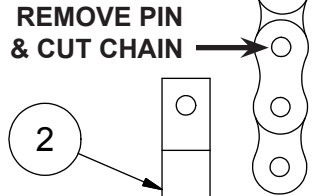
7	4	01801	CONNECTION LINK
6	2	01807	DOOR CHAIN
5	2	74210	1/8" x 1" Lg COTTER PIN
4	4	1133626	1/2" LOCK WASHER
3	4	1136510	1/2"-13 HEAVY HEX NUT ZP
2	2	0121	CHAIN ROD, 42"
1	1	770135	BI PARTING REGULAR IOWER PANEL
ITEM	QTY	PART NO	DESCRIPTION



THE PELLE COMPANY

FREIGHT DOORS | CAR GATES | CAR ENCLOSURES
TECHNICAL SUPPORT 1-800-787-5020 ext 275

36

Guide No. 267-EN
ATTENDANT OPERATED
ENTRANCE

Date: Oct 26/2020

22. PULL STRAPS (MANUAL OPERATION)

770147-27

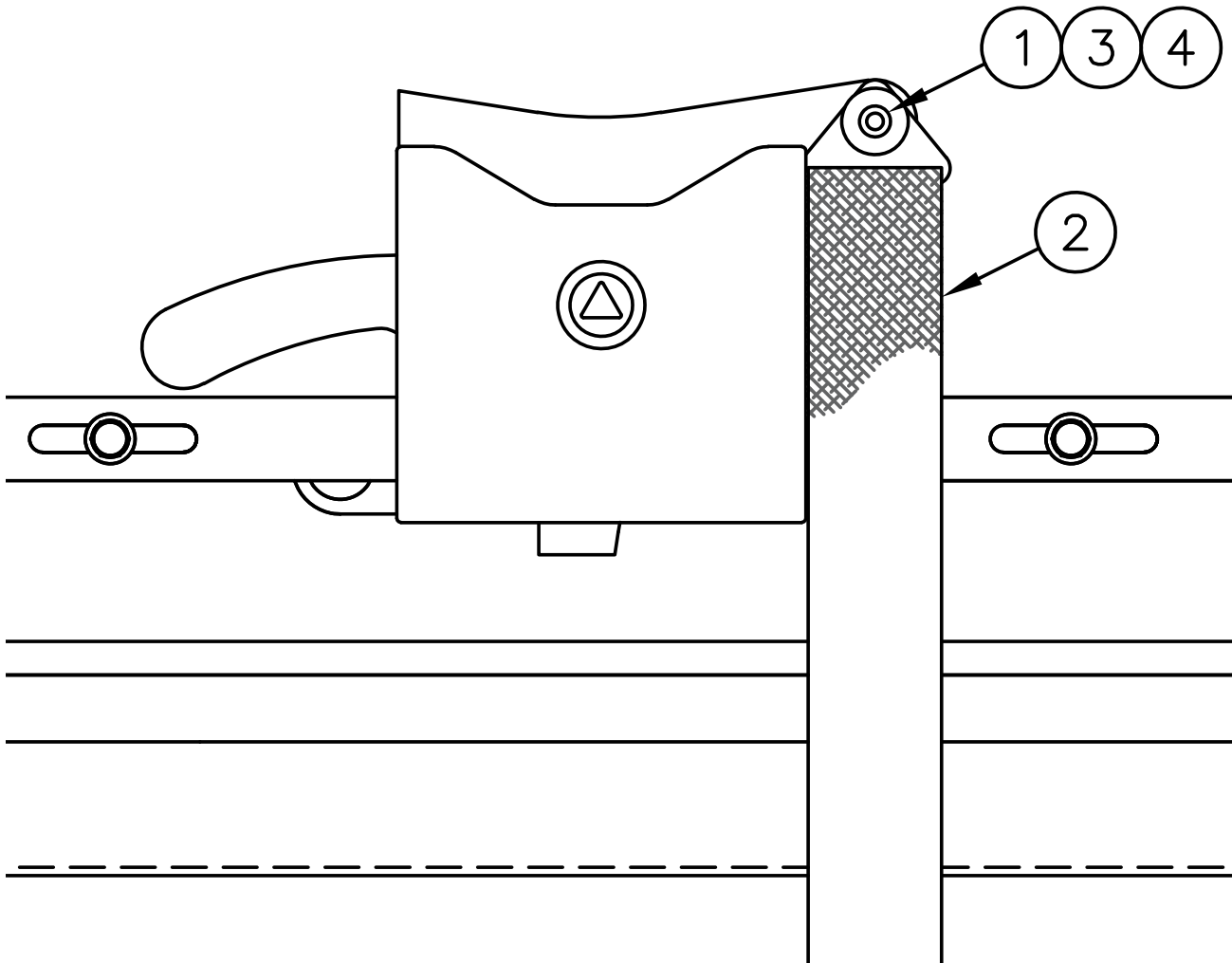

VIEW FROM HOISTWAY
(BACK OF DOOR PANEL)

260018

HARDWARE BAG

ITEM	QTY	PART NO	DESCRIPTION
4	2	1133220	3/8" FLAT WASHER Z
3	1	29291	.375-16 x 2.500 TRUSS HD SCREW ZP
2	2	034315	PULL STRAP - 36 IN. LONG
1	7	1137024	3/8"-16 NULOCK NUT



THE PEELLE COMPANY

FREIGHT DOORS | CAR GATES | CAR ENCLOSURES

TECHNICAL SUPPORT 1-800-787-5020 ext 275

37

Guide No. 267-EN
ATTENDANT OPERATED
ENTRANCE

Date: Oct 26/2020

22.1. RATCHET PIECE AND ROLLER KEEPER

770480-04

Install the roller keeper and ratchet piece. use two shims for initial installation. Position will be adjusted later.

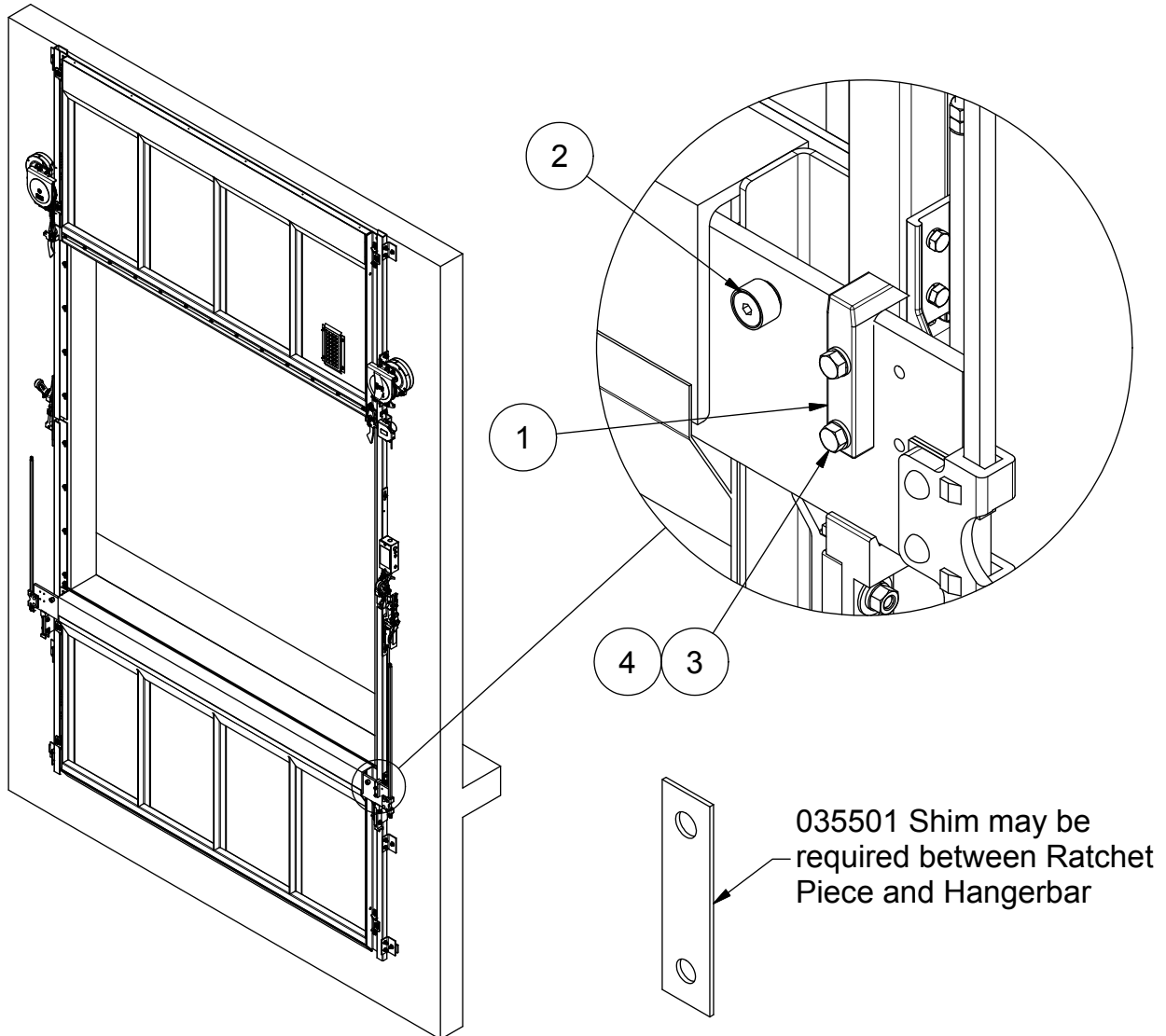

4	2	800005	WASHER, LOCK, 3/8"
3	2	110120345	3/8"-16 x 1 1/4" HH BOLT
2	2	06592	ROLLER KEEPER ASSY
1	1	235534	RATCHET PIECE
ITEM	QTY	PART NO	DESCRIPTION



THE PEELLE COMPANY

FREIGHT DOORS | CAR GATES | CAR ENCLOSURES
TECHNICAL SUPPORT 1-800-787-5020 ext 275

38

Guide No. 267-EN
ATTENDANT OPERATED
ENTRANCE

Date: Oct 26/2020

23. FINAL ADJUSTMENTS

770147-22

PERFORM THE FINAL ADJUSTMENTS ON THE LISTED COMPONENTS.

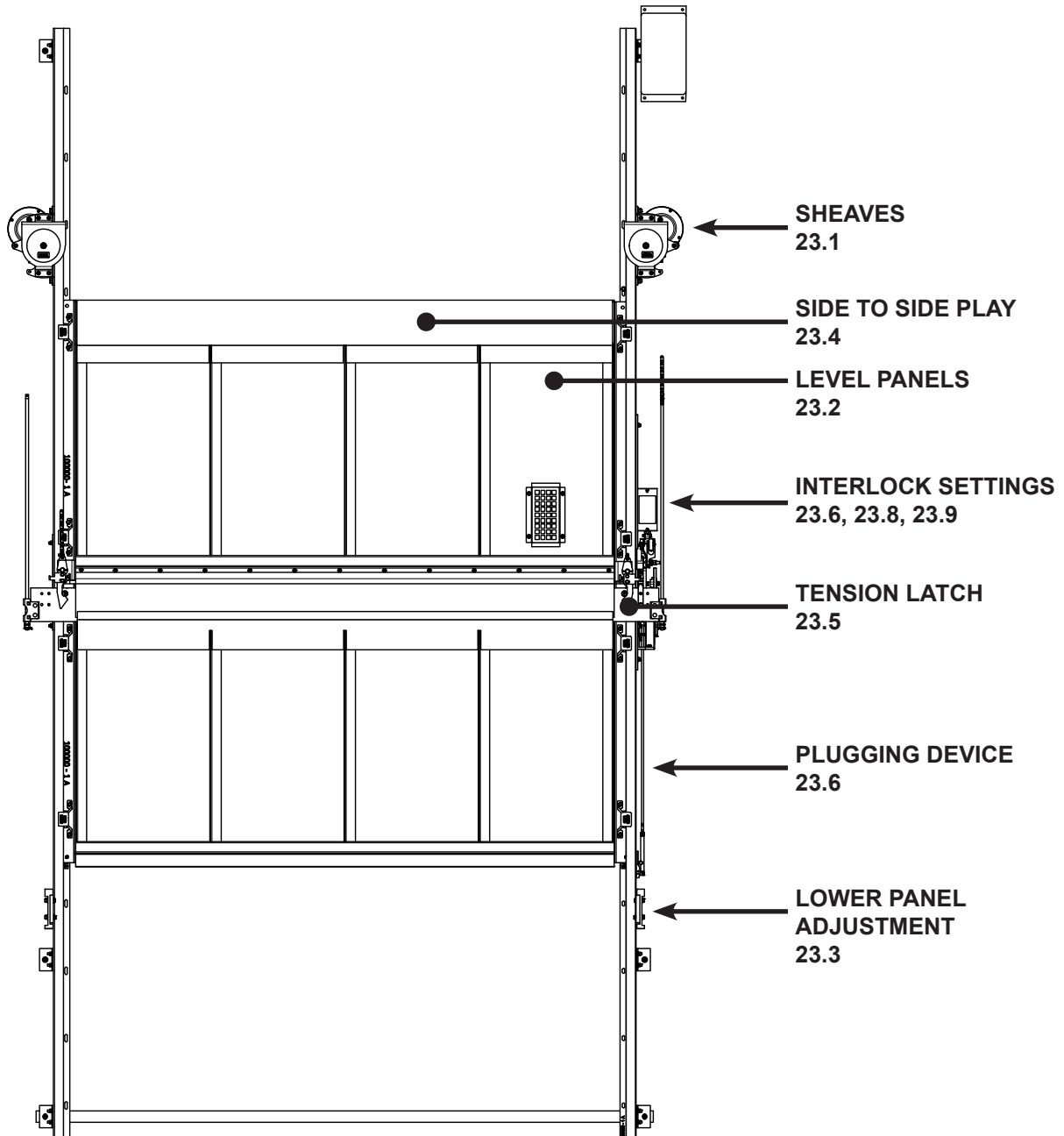

THE PELLE COMPANY

FREIGHT DOORS | CAR GATES | CAR ENCLOSURES

TECHNICAL SUPPORT 1-800-787-5020 ext 275

39

Guide No. 267-EN
ATTENDANT OPERATED
ENTRANCE

Date: Oct 26/2020

23.1. MANUAL SHEAVE ADJUSTMENT

770147-34

Adjust the door sheave using the mounting slots, ensure the center of sheave and chain rod are in line (keep door chain perfectly vertical).

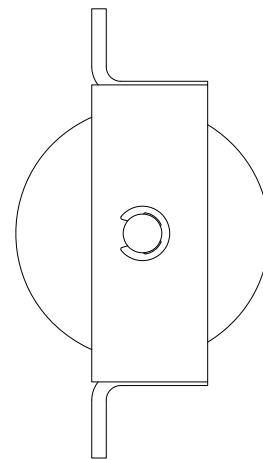
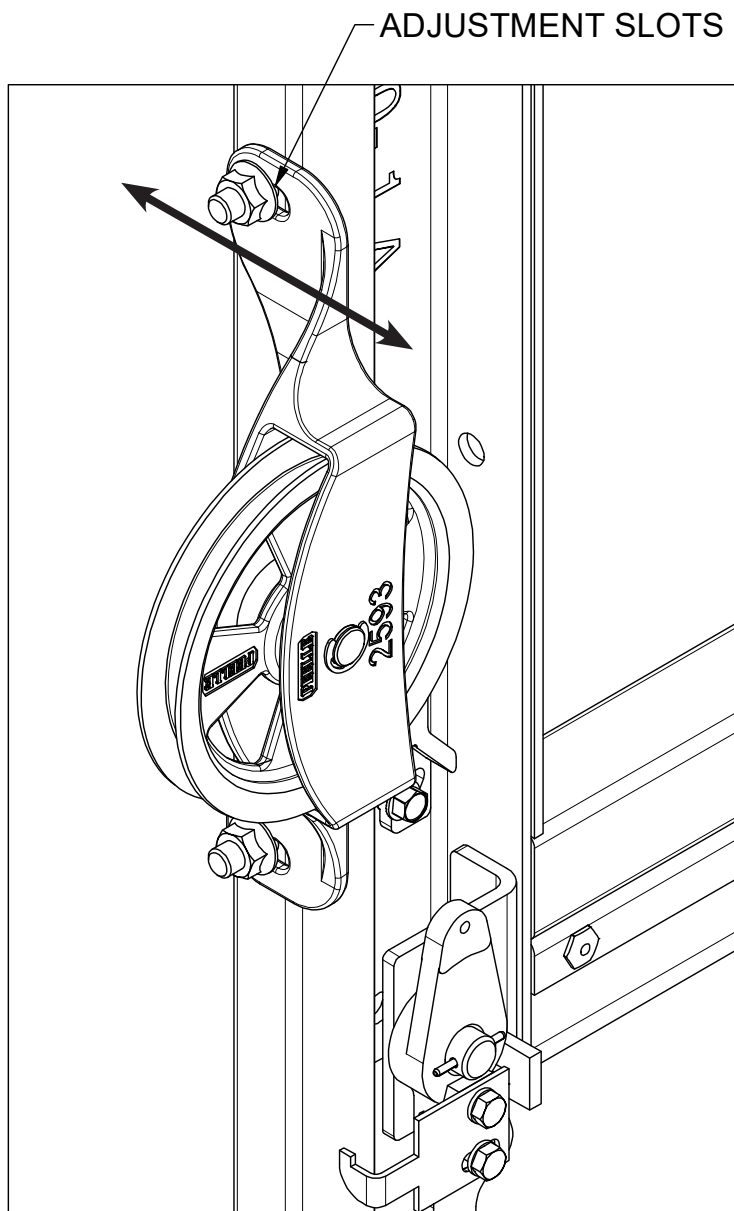

(OPTIONAL)
2580
MANUAL SHEAVE



THE PEELLE COMPANY

FREIGHT DOORS | CAR GATES | CAR ENCLOSURES

TECHNICAL SUPPORT 1-800-787-5020 ext 275

23.2. LEVEL THE PANELS

770514-01

Check the opening and closing sequence and ensure panels are level and parallel with each other during the full open and close operation.

- Eliminate gap between panels in closed position. With the doors fully closed and with the side tension latch hooks loosened and positioned temporarily out of the way, adjust the nuts on the chain rods to eliminate the panel gap across the opening.
- Move nuts up on the rod of the side of the door that tends to stay apart. This provides a closed meeting between panels in the closed position.
- With door panels closed. Move nuts on both rods downward the same distance each side. Move nuts down to cotter pin. This allows for the easy future chain stretch adjustment. If there is slack in the chain, remove chain links.

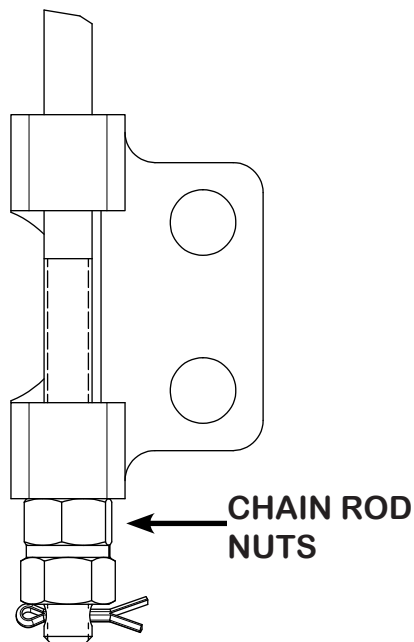
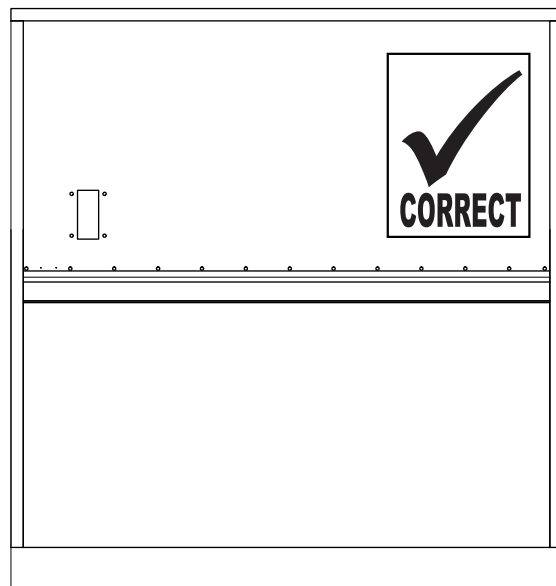
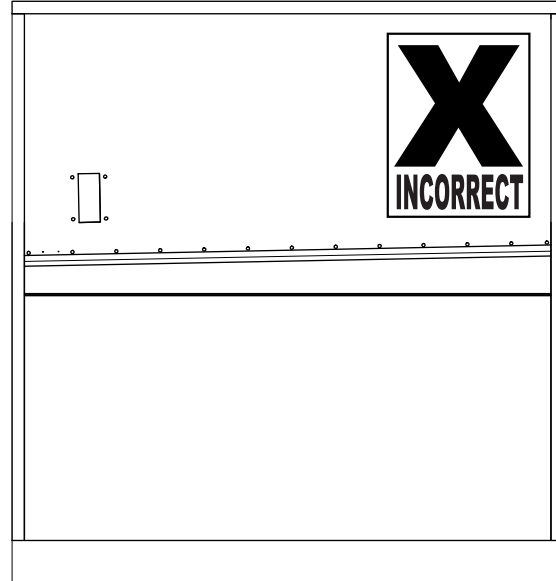

THE PEELLE COMPANY

FREIGHT DOORS | CAR GATES | CAR ENCLOSURES

TECHNICAL SUPPORT 1-800-787-5020 ext 275

41

Guide No. 267-EN
ATTENDANT OPERATED
ENTRANCE

Date: Oct 26/2020

23.3. LOWER PANEL ADJUSTMENT

770468-23

Ensure Lower Panel Trucking Sill is level with the building sill.

If final adjustment is needed, adjust the 04204 Sill Stop Casting, to raise or lower the panel open position.

There is an 8-way adjustment by flipping, rotating and spacing the stop casting.

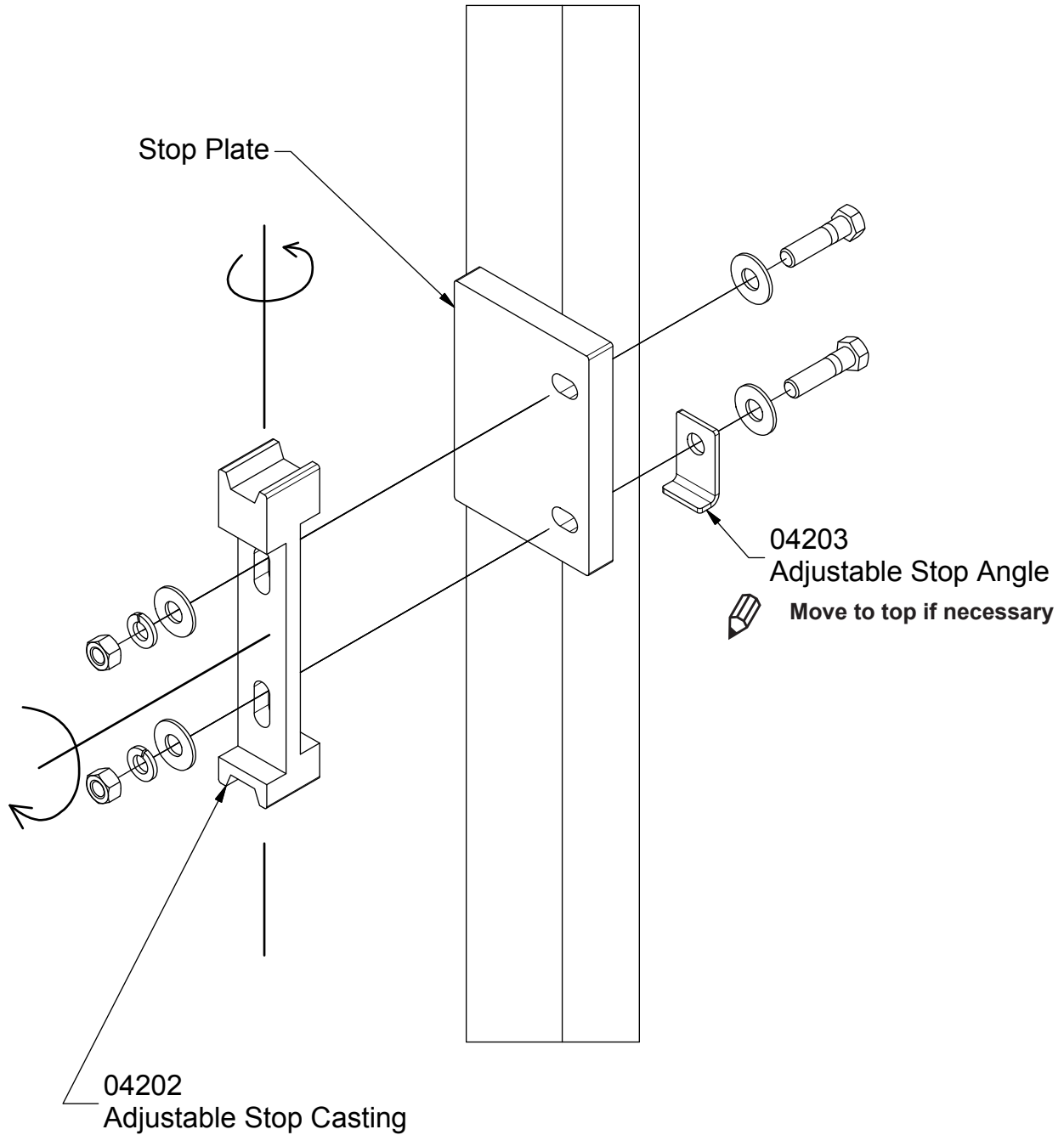

23.4. SIDE TO SIDE PLAY

770147-21

Guide shoes have angled slots.

Adjust the gap between Guide Shoe and rail to 1/16"
[1.58 mm] each side.

Allow Maximum panel movement between guides 1/8"
[3.175 mm].

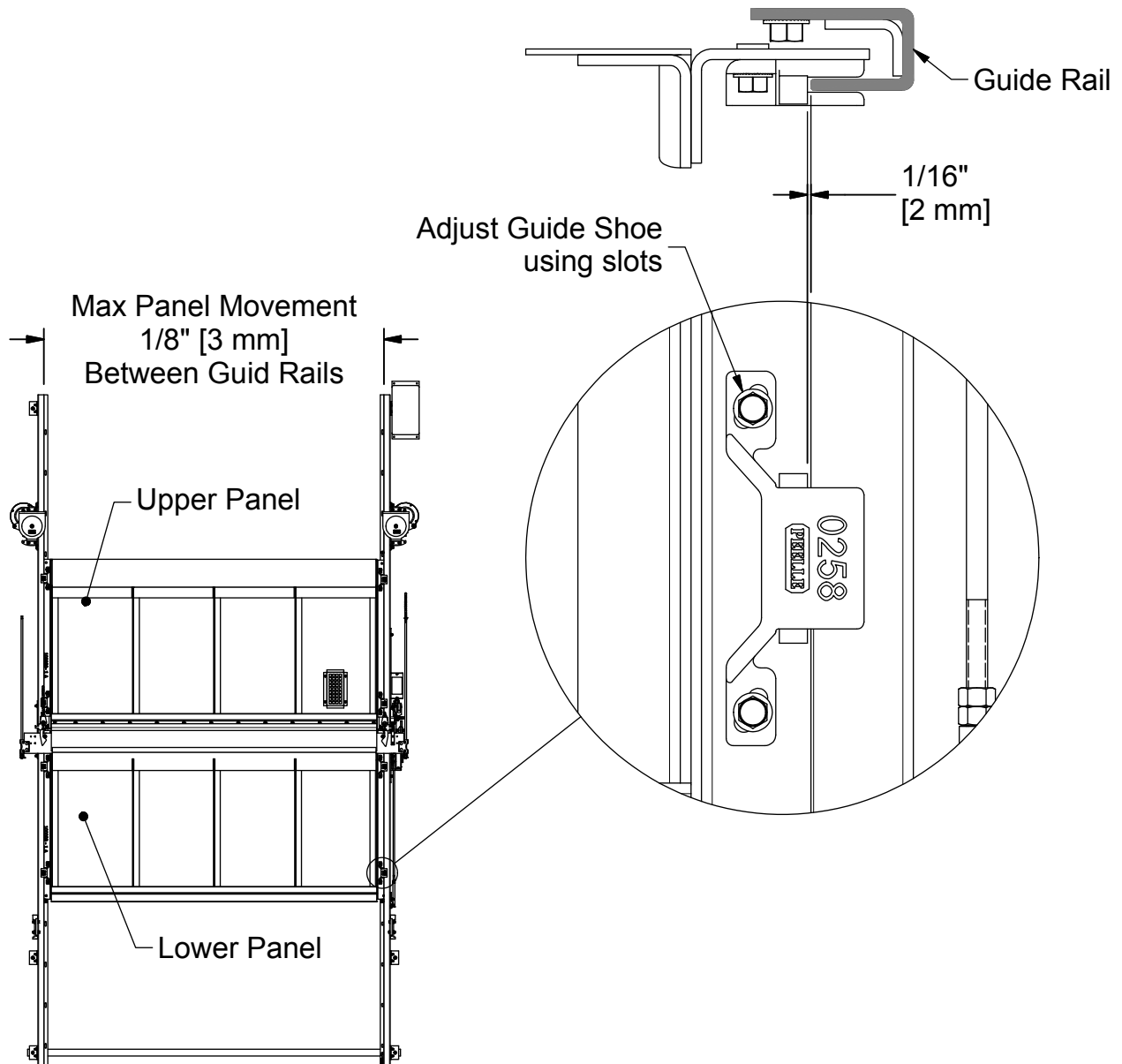

THE PEELLE COMPANY

FREIGHT DOORS | CAR GATES | CAR ENCLOSURES
TECHNICAL SUPPORT 1-800-787-5020 ext 275

43

Guide No. 267-EN
ATTENDANT OPERATED
ENTRANCE

Date: Oct 26/2020

23.5. TENSION LATCH ADJUSTMENT

770468-26

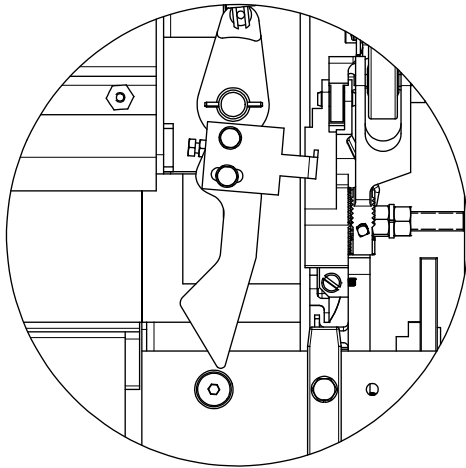

Bring panels together slowly and position the tension latch point just off center of the roller keeper.

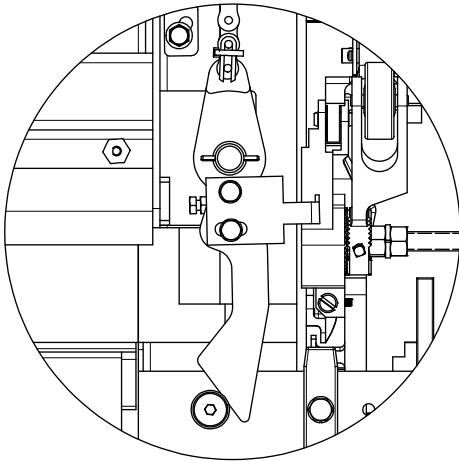

Bring panels closer together, ensure the tension latch pivots out and around the roller keeper.

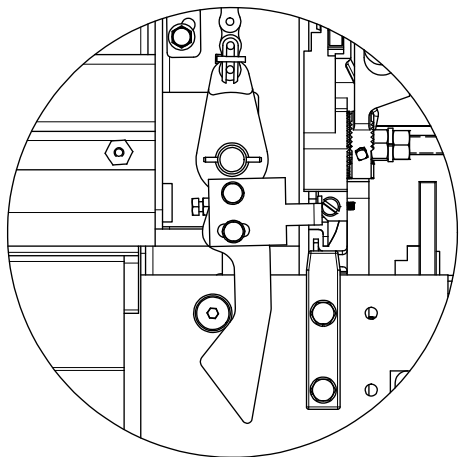

When door panels are in the fully closed the tension latch should be snug against the roller keeper.

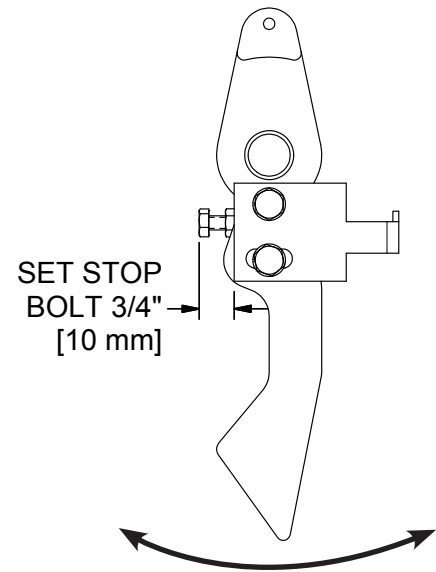

SET STOP
BOLT 3/4"
[10 mm]

LOOSEN BOLTS
TO ADJUST (PIVOT)
THE TENSION LATCH



THE PEELLE COMPANY

FREIGHT DOORS | CAR GATES | CAR ENCLOSURES

TECHNICAL SUPPORT 1-800-787-5020 ext 275

23.6. ADJUST THE TAMPER RESISTANT PLUGGING DEVICE

The tamper resistant plugging device is made up of two components, the plugging rod and the plugging trigger.

The plugging rod is cut to the proper length for the door from the factory. It must be installed before the lock is pinned into its vertical fixed position.

The plugging trigger is located on the door rail below the opening. Loosen and slide the interlock so that the plugging rod inserts into the hole. Slide the interlock into place and turn the rod for proper adjustment. Lock the rod in place with the supplied nuts.

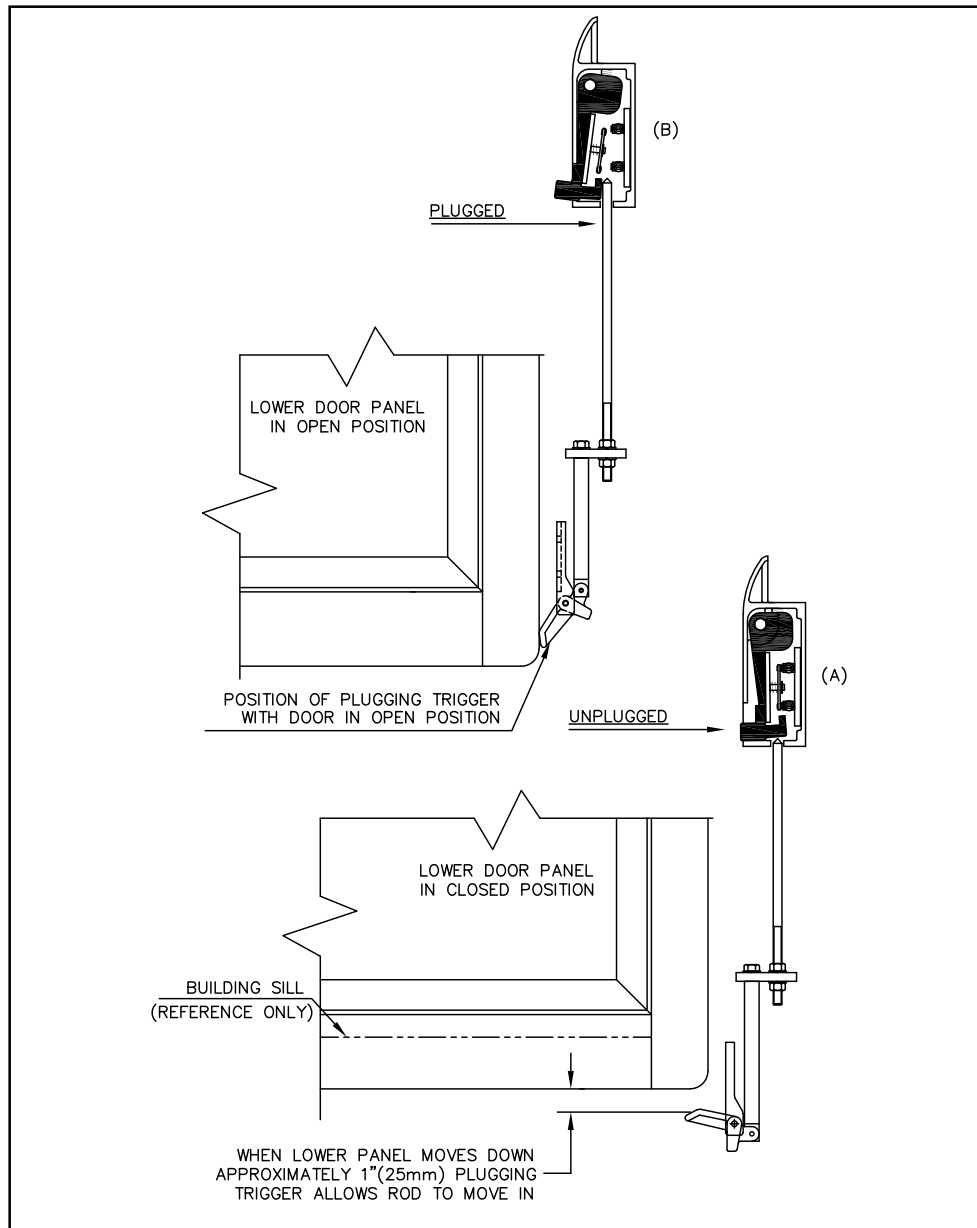

Figure 4 - Plugging Trigger



THE PELLE COMPANY

FREIGHT DOORS | CAR GATES | CAR ENCLOSURES

TECHNICAL SUPPORT 1-800-787-5020 ext 275

45

Guide No. 267-EN
ATTENDANT OPERATED
ENTRANCE

Date: Oct 26/2020

23.7. RO INTERLOCK & BAR KEEPER SET AND PIN

770147-36

- 1) Once the door panels are in place and adjusted.
- 2) Locate the existing 3/8" [10mm] hole in door rails, one for the RO lock and one for the Bar Keeper.
- 3) You will need to open the doors in order to locate the pinning holes.
- 4) Use holes as a template and drill a clear 3/8" [10mm] hole through the RO Mounting Plate and the Bar Keeper.
- 5) Bolt and pin the Interlock and Bar Keeper in place.
- 6) The RO Interlock and Bar Keeper will not be adjusted again in life of product. Only the panels will be adjusted.

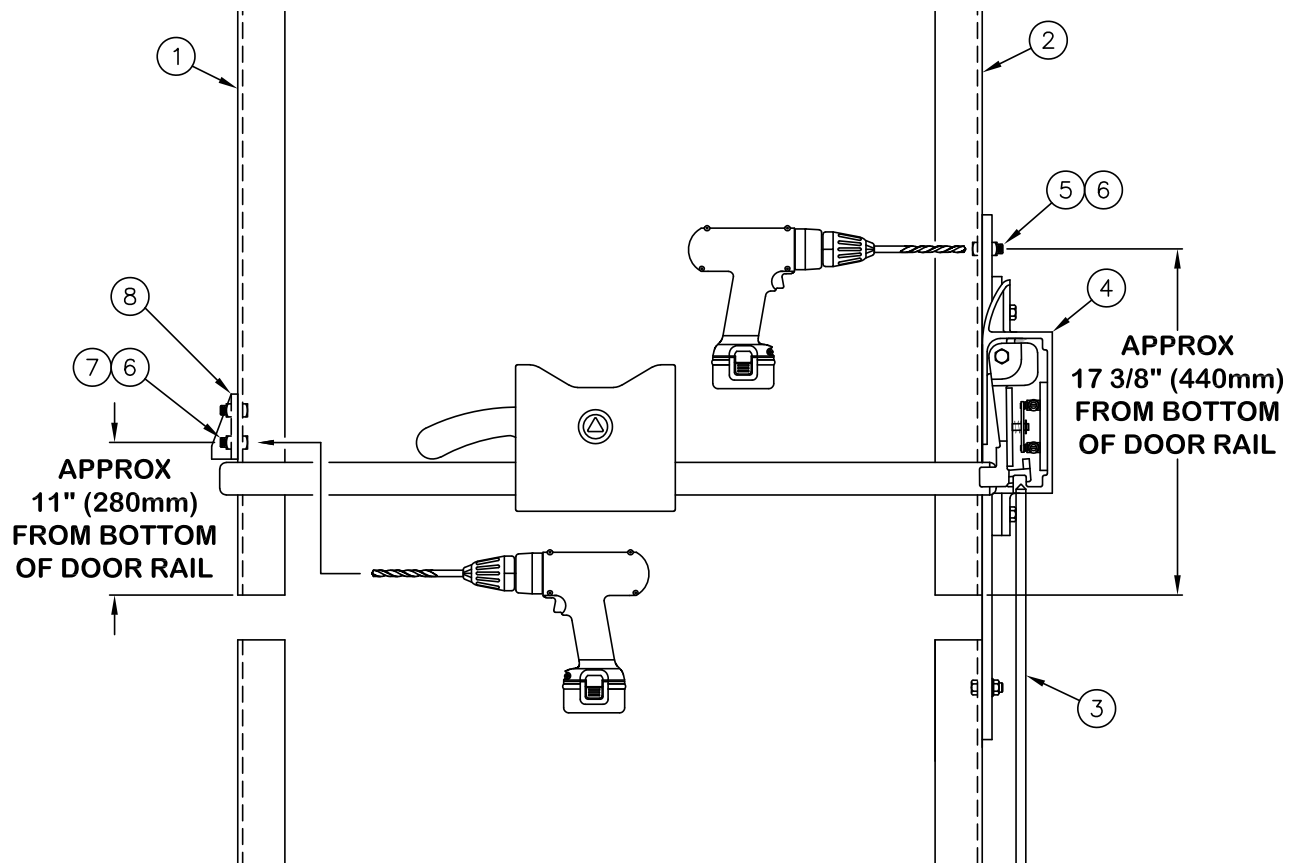

8	1	DS3	BAR KEEPER
7	1	110120345	3/8-16 x 1 1/4 HH BOLT ZP
6	2	97244	3/8-16 SERRATED FLANGE NUT Z
5	1	800061	3/8-16 x 1 HH BOLT ZP
4	1	DS10	RO INTERLOCK AND MOUNTING PLATE ASSY
3	1	DS8	PLUG ROD ASSY
2	1	770145	RIGHTHAND RAIL ASSY
1	1	770235	LEFTHAND RAIL ASSY
ITEM	QTY	PART NO	DESCRIPTION



THE PEELLE COMPANY

FREIGHT DOORS | CAR GATES | CAR ENCLOSURES

TECHNICAL SUPPORT 1-800-787-5020 ext 275

46

Guide No. 267-EN

ATTENDANT OPERATED
ENTRANCE

Date: Oct 26/2020

23.8. INSTALL KEEPER HOOK, AND SET POSITION OF PARKING DEVICE (MECHANICAL LOCK)

The keeper hook for the interlock must be bolted to the hanger bar on the lower panel. This lower panel lock keeper hook and the upper panel lock keeper, prevent the door panels from being opened when the roller is extended (locked).

Set the ratchet 8mm [5/16in] below the lower keeper hook with the doors closed, chains adjusted and side-tension-latches working; set the 8mm [5/16in] dimension by moving the mechanical lock up or down in the slots, then securely tightening the bolts.

Ensure the keeper hook has at least 8mm [5/16in] locking engagement with the top of the ratchet. (*see pg 47, Figure 5*). Ensure keeper hook clears the ratchet teeth while opening the door. Use shims to space the hook in or out to obtain clearance if necessary.

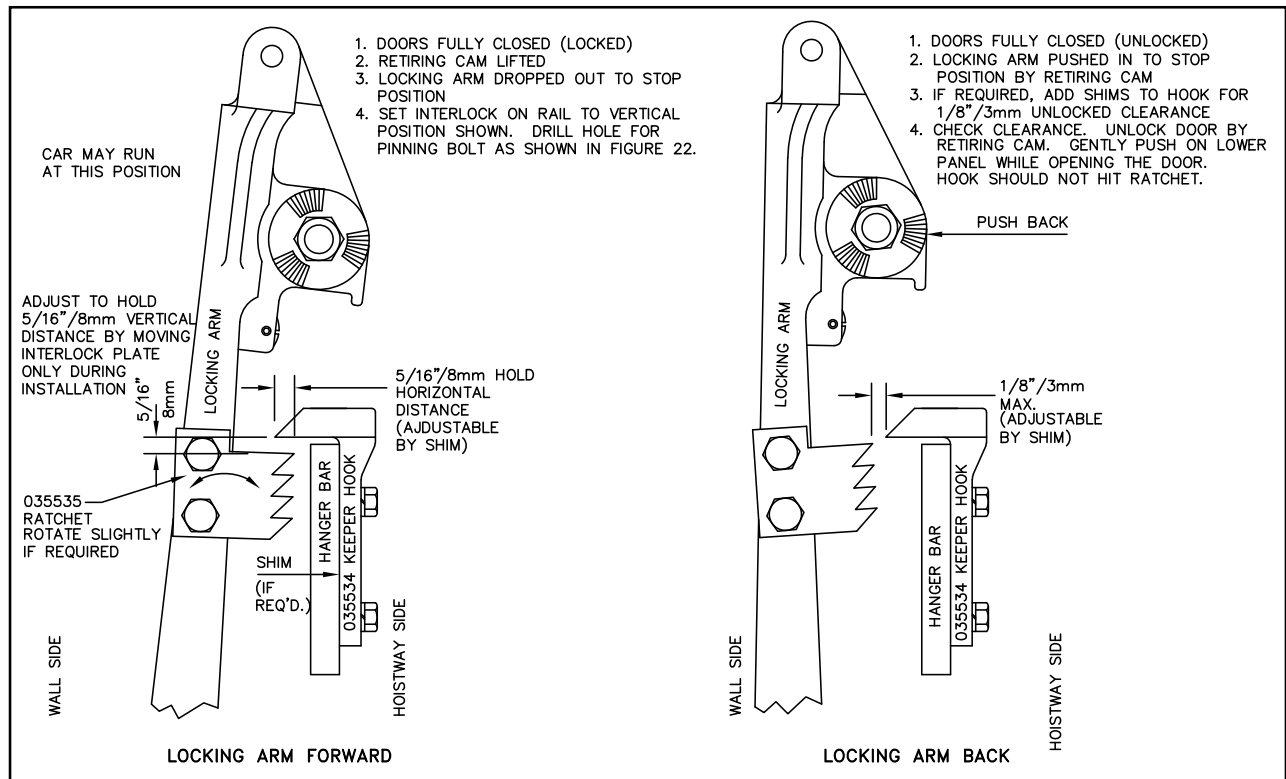

Figure 5 - Locking Arm



THE PEELLE COMPANY

FREIGHT DOORS | CAR GATES | CAR ENCLOSURES

TECHNICAL SUPPORT 1-800-787-5020 ext 275

23.9. SET THE ROLLER ARM

The roller arm of the interlock is normally attached in the factory. Make sure locking arm spring is in place and working.

Ensure locking arm falls forward, easily and fully and rests on the mechanical stop (*see pg 48, Figure 6*).

Stand on landing side and make sure the door panels cannot be shaken open when they are closed and locked (retiring cam held up or elevator away). Try again while you are pushing the lower panel toward the elevator (retiring cam held up or elevator away).

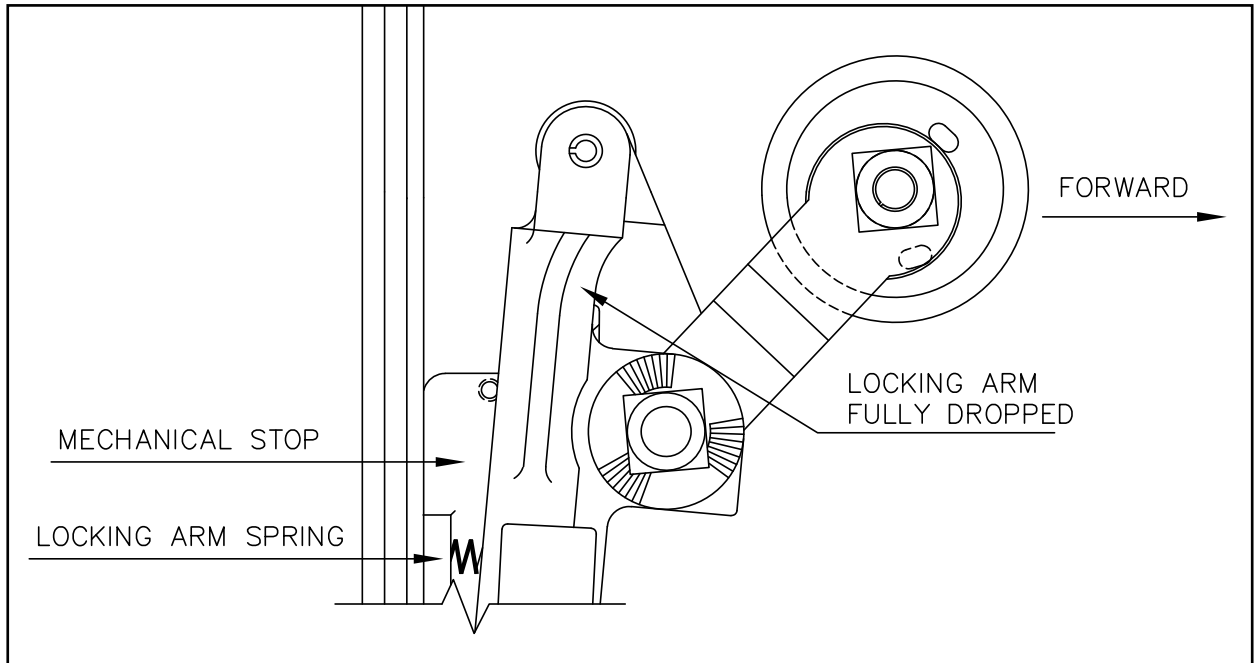

Figure 6 - Roller Arm Setting



THE PEELLE COMPANY

FREIGHT DOORS | CAR GATES | CAR ENCLOSURES

TECHNICAL SUPPORT 1-800-787-5020 ext 275

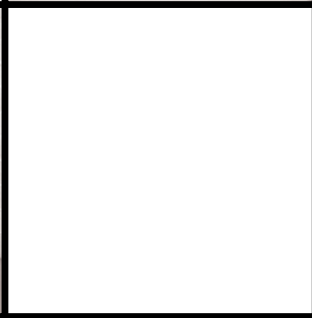

THE PEELLE COMPANY

FREIGHT DOORS | CAR GATES | CAR ENCLOSURES
TECHNICAL SUPPORT 1-800-787-5020 ext 275

Guide No. 267-EN
ATTENDANT OPERATED
ENTRANCE

Date: Oct 26/2020